

Silicon NPN Planar RF Transistor

Electrostatic sensitive device.
Observe precautions for handling.



Applications

RF amplifier up to GHz range specially for wide band antenna amplifier.

Features

- High power gain
- Low noise figure
- High transition frequency

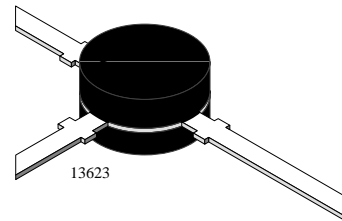
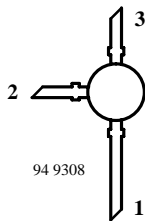

BFR91 Marking: BFR91
Plastic case (TO 50)
1 = Collector, 2 = Emitter, 3 = Base

Absolute Maximum Ratings

$T_{amb} = 25^{\circ}\text{C}$, unless otherwise specified

Parameter	Test Conditions	Symbol	Value	Unit
Collector-base voltage		V_{CBO}	20	V
Collector-emitter voltage		V_{CEO}	12	V
Emitter-base voltage		V_{EBO}	2	V
Collector current		I_C	50	mA
Total power dissipation	$T_{amb} \leq 60^{\circ}\text{C}$	P_{tot}	300	mW
Junction temperature		T_j	150	$^{\circ}\text{C}$
Storage temperature range		T_{stg}	-65 to +150	$^{\circ}\text{C}$

Maximum Thermal Resistance

$T_{amb} = 25^{\circ}\text{C}$, unless otherwise specified

Parameter	Test Conditions	Symbol	Value	Unit
Junction ambient	on glass fibre printed board (40 x 25 x 1.5) mm ³ plated with 35 μm Cu	R_{thJA}	300	K/W

Electrical DC Characteristics

$T_{amb} = 25^{\circ}\text{C}$, unless otherwise specified

Parameter	Test Conditions	Symbol	Min	Typ	Max	Unit
Collector cut-off current	$V_{CE} = 20\text{ V}, V_{BE} = 0$	I_{CES}			100	μA
Collector-base cut-off current	$V_{CB} = 20\text{ V}, I_E = 0$	I_{CBO}			100	nA
Emitter-base cut-off current	$V_{EB} = 2\text{ V}, I_C = 0$	I_{EBO}			10	μA
Collector-emitter breakdown voltage	$I_C = 1\text{ mA}, I_B = 0$	$V_{(BR)CEO}$	12			V
DC forward current transfer ratio	$V_{CE} = 5\text{ V}, I_C = 30\text{ mA}$	h_{FE}	25	50	150	

Electrical AC Characteristics

$T_{amb} = 25^{\circ}\text{C}$, unless otherwise specified

Parameter	Test Conditions	Symbol	Min	Typ	Max	Unit
Transition frequency	$V_{CE} = 5\text{ V}, I_C = 30\text{ mA}, f = 500\text{ MHz}$	f_T		5		GHz
Collector-base capacitance	$V_{CB} = 10\text{ V}, f = 1\text{ MHz}$	C_{cb}		0.5		pF
Collector-emitter capacitance	$V_{CE} = 10\text{ V}, f = 1\text{ MHz}$	C_{ce}		0.3		pF
Emitter-base capacitance	$V_{EB} = 0.5\text{ V}, f = 1\text{ MHz}$	C_{eb}		1.4		pF
Noise figure	$V_{CE} = 5\text{ V}, I_C = 2\text{ mA}, f = 500\text{ MHz}, Z_S = 50\ \Omega$	F		1.9		dB
Power gain	$V_{CE} = 5\text{ V}, I_C = 30\text{ mA}, Z_L = Z_{Lopt}, f = 500\text{ MHz}$	G_{pe}		18		dB
	$V_{CE} = 5\text{ V}, I_C = 30\text{ mA}, Z_L = Z_{Lopt}, f = 800\text{ MHz}$	G_{pe}		13		dB
Linear output voltage – two tone intermodulation test	$V_{CE} = 5\text{ V}, I_C = 30\text{ mA}, d_{IM} = 60\text{ dB}, f_1 = 806\text{ MHz}, f_2 = 810\text{ MHz}, Z_S = Z_L = 50\ \Omega$	$V_1 = V_2$		240		mV
Third order intercept point	$V_{CE} = 5\text{ V}, I_C = 30\text{ mA}, f = 800\text{ MHz}$	IP_3		30		dBm



Common Emitter S-Parameters

$Z_0 = 50 \Omega$, $T_{amb} = 25^\circ\text{C}$, unless otherwise specified

V_{CE}/V	I_C/mA	f/MHz	S11		S21		S12		S22	
			LIN MAG	ANG	LIN MAG	ANG	LIN MAG	ANG	LIN MAG	ANG
				deg		deg		deg		deg
5	2	100	0.84	-27.4	6.23	156.5	0.03	73.9	0.95	-11.1
		300	0.61	-72.6	4.66	122.5	0.07	52.9	0.79	-24.2
		500	0.44	-107.4	3.50	100.9	0.09	44.4	0.68	-29.9
		800	0.33	-152.3	2.48	79.1	0.10	41.4	0.60	-35.6
		1000	0.32	-177.9	2.10	68.3	0.11	41.9	0.57	-39.8
		1200	0.32	160.1	1.82	57.7	0.13	42.8	0.55	-44.4
		1500	0.37	134.5	1.52	44.4	0.15	44.3	0.51	-51.8
		1800	0.42	116.1	1.33	32.4	0.17	45.1	0.47	-60.0
	2000	0.46	106.5	1.23	25.8	0.20	44.4	0.45	-66.2	
	5	100	0.66	-39.9	12.45	146.3	0.02	70.2	0.88	-17.6
		300	0.37	-93.5	7.40	109.5	0.05	56.7	0.63	-29.0
		500	0.25	-131.7	4.97	91.2	0.07	55.6	0.53	-30.9
		800	0.20	-178.3	3.31	73.7	0.10	55.6	0.47	-34.8
		1000	0.21	158.6	2.73	64.5	0.12	54.8	0.45	-38.5
		1200	0.23	140.2	2.34	55.5	0.14	52.9	0.43	-42.8
		1500	0.29	121.0	1.94	43.9	0.18	49.6	0.39	-49.9
		1800	0.34	107.3	1.68	33.0	0.21	46.1	0.36	-57.1
	2000	0.38	99.8	1.56	26.3	0.23	43.0	0.33	-62.6	
	10	100	0.46	-53.5	18.29	136.4	0.02	69.5	0.79	-23.5
		300	0.22	-114.2	8.93	101.4	0.05	64.5	0.52	-29.9
		500	0.16	-155.9	5.72	86.2	0.07	64.3	0.45	-29.9
		800	0.15	159.4	3.73	70.8	0.11	62.1	0.41	-33.4
		1000	0.18	141.2	3.06	62.7	0.13	59.5	0.39	-37.4
		1200	0.20	126.9	2.60	54.3	0.16	56.4	0.36	-41.8
1500		0.26	111.8	2.15	43.5	0.19	51.3	0.33	-48.7	
1800		0.31	102.4	1.86	33.1	0.23	46.3	0.29	-55.6	
2000	0.35	96.4	1.72	26.9	0.25	42.4	0.27	-60.8		



V _{CE} /V	I _C /mA	f/MHz	S11		S21		S12		S22	
			LIN MAG	ANG	LIN MAG	ANG	LIN MAG	ANG	LIN MAG	ANG
				deg		deg		deg		deg
5	20	100	0.27	-71.3	23.16	126.9	0.02	72.1	0.69	-28.0
		300	0.14	-141.2	9.82	95.9	0.04	71.4	0.44	-28.8
		500	0.12	177.1	6.15	82.6	0.07	70.0	0.39	-27.9
		800	0.14	141.0	3.97	68.9	0.11	65.5	0.36	-31.8
		1000	0.17	128.2	3.24	61.3	0.14	62.0	0.34	-36.2
		1200	0.19	118.3	2.76	53.4	0.16	58.0	0.32	-40.8
		1500	0.25	107.3	2.27	42.9	0.20	52.0	0.29	-47.7
		1800	0.30	99.6	1.97	32.9	0.24	46.3	0.25	-54.6
	2000	0.33	93.9	1.82	26.8	0.26	42.0	0.23	-59.6	
	30	100	0.19	-83.9	24.93	122.7	0.02	74.1	0.64	-29.2
		300	0.11	-158.3	10.08	93.8	0.04	74.2	0.42	-27.4
		500	0.12	165.1	6.27	81.5	0.07	72.0	0.37	-26.5
		800	0.15	135.0	4.03	68.1	0.11	66.6	0.35	-30.7
		1000	0.17	123.9	3.29	60.6	0.14	62.6	0.33	-35.3
		1200	0.19	115.7	2.79	52.9	0.17	58.6	0.31	-40.0
		1500	0.24	106.3	2.30	42.6	0.20	52.3	0.28	-46.9
1800		0.30	98.9	1.99	32.5	0.24	46.5	0.24	-53.6	
2000	0.33	94.1	1.84	26.4	0.26	42.1	0.22	-58.8		

Typical Characteristics ($T_{amb} = 25^{\circ}\text{C}$ unless otherwise specified)

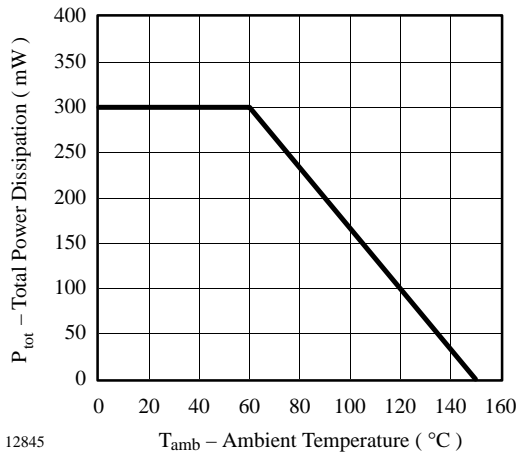

Figure 1. Total Power Dissipation vs. Ambient Temperature

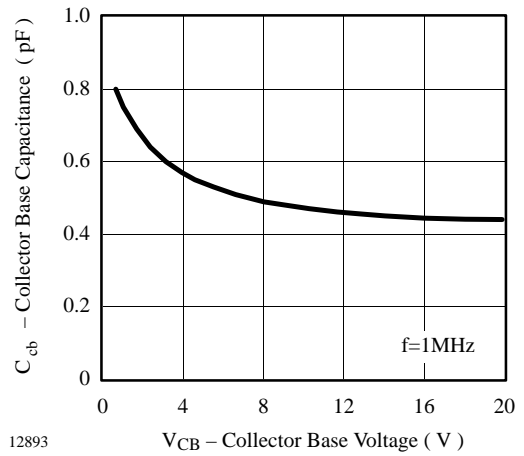

Figure 3. Collector Base Capacitance vs. Collector Base Voltage

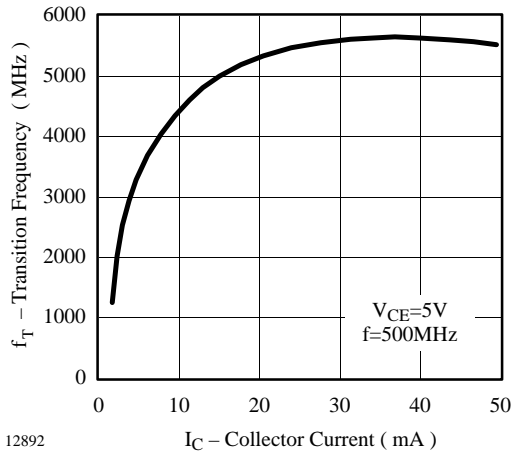

Figure 2. Transition Frequency vs. Collector Current

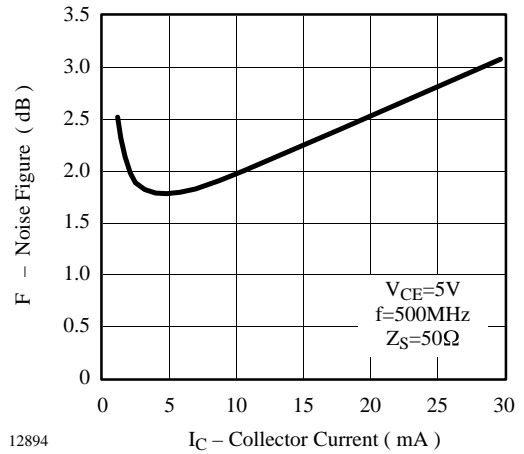

Figure 4. Noise Figure vs. Collector Current

$V_{CE} = 5 \text{ V}$, $I_C = 30 \text{ mA}$, $Z_0 = 50 \Omega$

S_{11}

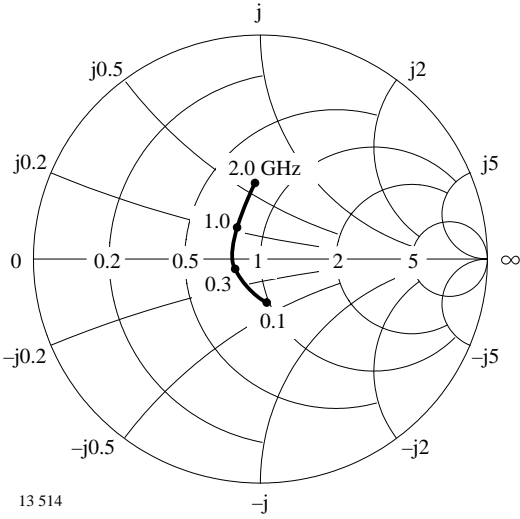

Figure 5. Input reflection coefficient

S_{12}

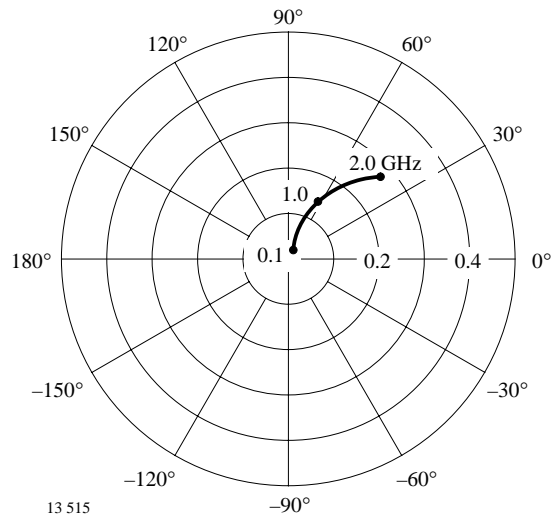

Figure 7. Reverse transmission coefficient

S_{21}

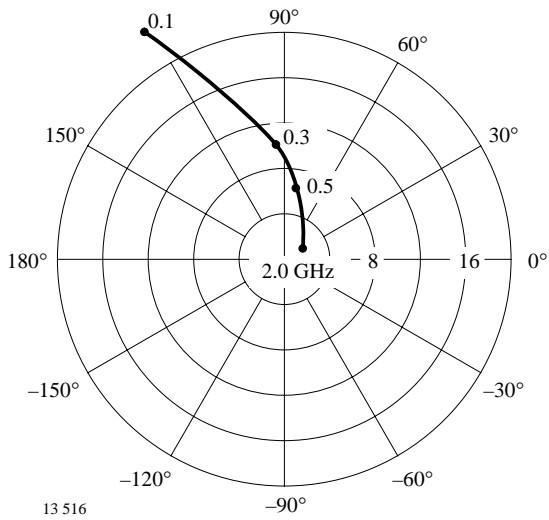

Figure 6. Forward transmission coefficient

S_{22}

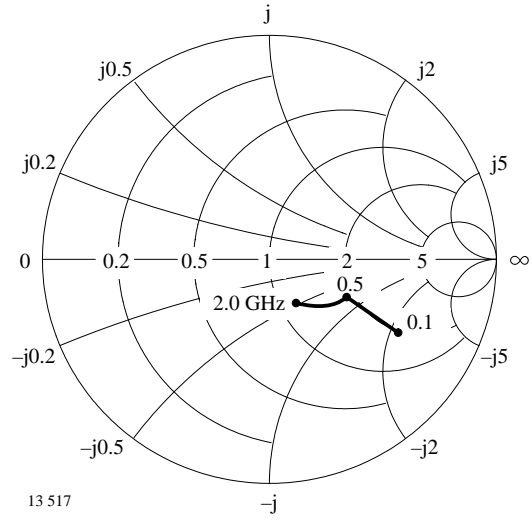
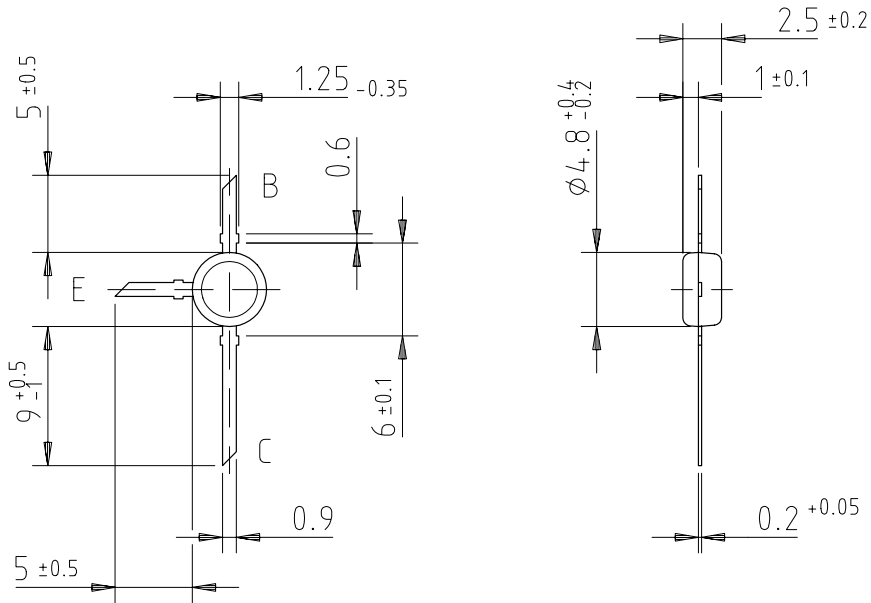
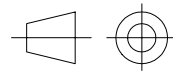

Figure 8. Output reflection coefficient

Dimensions of BFR91 in mm



96 12244



technical drawings
according to DIN
specifications