

DM54LS47/DM74LS47 BCD to 7-Segment Decoder/Driver with Open-Collector Outputs

General Description

The [∗]LS47 accepts four lines of BCD (8421) input data, generates their complements internally and decodes the data with seven AND/OR gates having open-collector outputs to drive indicator segments directly. Each segment output is guaranteed to sink 24 mA in the ON (LOW) state and withstand 15V in the OFF (HIGH) state with a maximum leakage current of 250 μ A. Auxiliary inputs provided blanking, lamp test and cascadable zero-suppression functions.

Features

- Open-collector outputs
- Drive indicator segments directly
- Cascadable zero-suppression capability
- Lamp test input

Connection Diagram

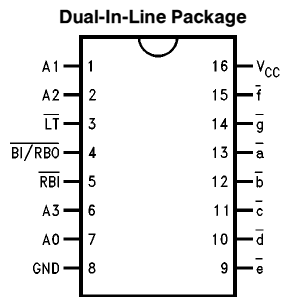

TL/F/9817-1

**Order Number DM54LS47J, DM54LS47W,
DM74LS47M or DM74LS47N**
See NS Package Number J16A, M16A, N16E or W16A

Pin Names	Description
A0–A3	BCD Inputs
$\overline{\text{RBI}}$	Ripple Blanking Input (Active LOW)
$\overline{\text{LT}}$	Lamp Test Input (Active LOW)
$\overline{\text{BI/RBO}}$	Blanking Input (Active LOW) or Ripple Blanking Output (Active LOW)
$\overline{\text{a}}-\overline{\text{g}}$	*Segment Outputs (Active LOW)

*OC—Open Collector

Absolute Maximum Ratings (Note)

If Military/Aerospace specified devices are required, please contact the National Semiconductor Sales Office/Distributors for availability and specifications.

Supply Voltage	7V
Input Voltage	7V
Operating Free Air Temperature Range	
DM54LS	-55°C to +125°C
DM74LS	0°C to +70°C
Storage Temperature Range	-65°C to +150°C

Note: The "Absolute Maximum Ratings" are those values beyond which the safety of the device cannot be guaranteed. The device should not be operated at these limits. The parametric values defined in the "Electrical Characteristics" table are not guaranteed at the absolute maximum ratings. The "Recommended Operating Conditions" table will define the conditions for actual device operation.

Recommended Operating Conditions

Symbol	Parameter	DM54LS47			DM74LS47			Units
		Min	Nom	Max	Min	Nom	Max	
V _{CC}	Supply Voltage	4.5	5	5.5	4.75	5	5.25	V
V _{IH}	High Level Input Voltage	2			2			V
V _{IL}	Low Level Input Voltage			0.7			0.8	V
I _{OH}	High Level Output Current $\bar{a} - \bar{g}$ @ 15V = V _{OH} *			-50			-250	μA
I _{OH}	High Level Output Current $\bar{B}\bar{I}/\bar{R}\bar{B}\bar{O}$						-50	μA
I _{OL}	Low Level Output Current			12			24	mA
T _A	Free Air Operating Temperature	-55		125	0		70	°C

*OFF state at $\bar{a} - \bar{g}$.

Electrical Characteristics

Over recommended operating free air temperature range (unless otherwise noted)

Symbol	Parameter	Conditions	Min	Typ (Note 1)	Max	Units
V _I	Input Clamp Voltage	V _{CC} = Min, I _I = -18 mA			-1.5	V
V _{OH}	High Level Output Voltage	V _{CC} = Min, I _{OH} = Max, V _{IL} = Max, $\bar{B}\bar{I}/\bar{R}\bar{B}\bar{O}$	DM54	2.4		V
			DM74	2.7	3.4	
I _{OFF}	Output High Current Segment Outputs	V _{CC} = 5.5V, V _O = 15V $\bar{a} - \bar{g}$			250	μA
V _{OL}	Low Level Output Voltage	V _{CC} = Min, I _{OL} = Max, V _{IH} = Min, $\bar{a} - \bar{g}$	DM54		0.4	V
			DM74	0.35	0.5	
		I _{OL} = 3.2 mA, $\bar{B}\bar{I}/\bar{R}\bar{B}\bar{O}$	DM74		0.5	
		I _{OL} = 12 mA, $\bar{a} - \bar{g}$	DM74	0.25	0.4	
I _I	Input Current @ Max Input Voltage	V _{CC} = Max, V _I = 7V	DM74		100	μA
		V _{CC} = Max, V _I = 10V	DM54			
I _{IH}	High Level Input Current	V _{CC} = Max, V _I = 2.7V			20	μA
I _{IL}	Low Level Input Current	V _{CC} = Max, V _I = 0.4V			-0.4	mA
I _{OS}	Short Circuit Output Current	V _{CC} = Max (Note 2), I _{OS} at $\bar{B}\bar{I}/\bar{R}\bar{B}\bar{O}$	DM54	-0.3	-2.0	mA
			DM74	-0.3	-2.0	
I _{CC}	Supply Current	V _{CC} = Max			13	mA

Note 1: All typicals are at V_{CC} = 5V, T_A = 25°C.

Note 2: Not more than one output should be shorted at a time, and the duration should not exceed one second.

Switching Characteristics at $V_{CC} = +5.0V, T_A = +25^\circ C$

Symbol	Parameter	Conditions	$R_L = 665\Omega$		Units
			$C_L = 15\text{ pF}$		
			Min	Max	
t_{PLH} t_{PHL}	Propagation Delay An to $\bar{a}-\bar{g}$			100 100	ns
t_{PLH} t_{PHL}	Propagation Delay \bar{RBI} to $\bar{a}-\bar{g}^*$			100 100	ns

* \bar{LT} = HIGH, A0-A3 = LOW

Functional Description

The 'LS47 decodes the input data in the pattern indicated in the Truth Table and the segment identification illustration. If the input data is decimal zero, a LOW signal applied to the \bar{RBI} blanks the display and causes a multidigit display. For example, by grounding the \bar{RBI} of the highest order decoder and connecting its \bar{BI}/\bar{RBO} to \bar{RBI} of the next lowest order decoder, etc., leading zeros will be suppressed. Similarly, by grounding \bar{RBI} of the lowest order decoder and connecting its \bar{BI}/\bar{RBO} to \bar{RBI} of the next highest order decoder, etc., trailing zeros will be suppressed. Leading and trailing zeros can be suppressed simultaneously by using external gates, i.e.: by driving \bar{RBI} of a intermediate decoder from an OR

gate whose inputs are \bar{BI}/\bar{RBO} of the next highest and lowest order decoders. \bar{BI}/\bar{RBO} also serves as an unconditional blanking input. The internal NAND gate that generates the \bar{RBO} signal has a resistive pull-up, as opposed to a totem pole, and thus \bar{BI}/\bar{RBO} can be forced LOW by external means, using wired-collector logic. A LOW signal thus applied to \bar{BI}/\bar{RBO} turns off all segment outputs. This blanking feature can be used to control display intensity by varying the duty cycle of the blanking signal. A LOW signal applied to \bar{LT} turns on all segment outputs, provided that \bar{BI}/\bar{RBO} is not forced LOW.

Logic Diagram

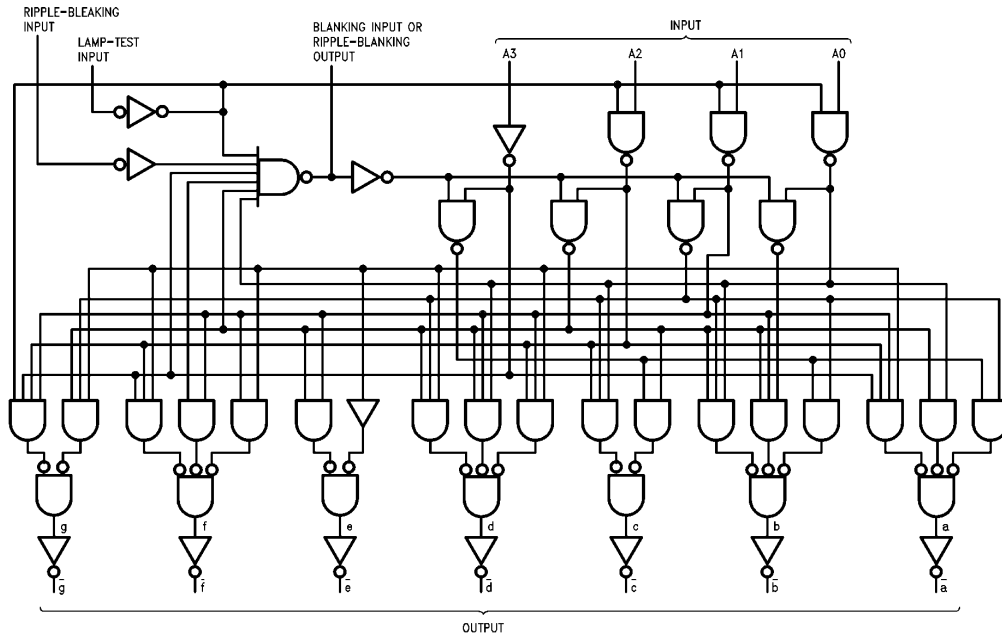

TL/F/9817-3

Numerical Designations—Resultant Displays

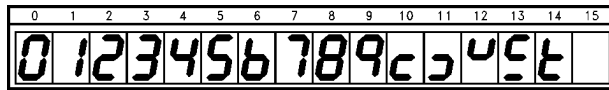

TL/F/9817-4

Logic Symbol

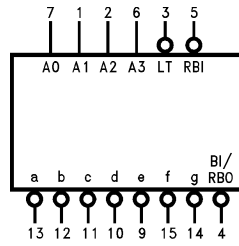

TL/F/9817-2

V_{CC} = Pin 16
GND = Pin 8

Truth Table

Decimal or Function	Inputs							Outputs							Note
	\overline{LT}	\overline{RBI}	A3	A2	A1	A0	$\overline{BI/RBO}$	\overline{a}	\overline{b}	\overline{c}	\overline{d}	\overline{e}	\overline{f}	\overline{g}	
0	H	H	L	L	L	L	H	L	L	L	L	L	L	H	1
1	H	X	L	L	L	H	H	H	L	L	H	H	H	H	1
2	H	X	L	L	H	L	H	L	L	H	L	L	H	L	
3	H	X	L	L	H	H	H	L	L	L	L	H	H	L	
4	H	X	L	H	L	L	H	H	L	L	H	H	L	L	
5	H	X	L	H	L	H	H	L	H	L	L	H	L	L	
6	H	X	L	H	H	L	H	H	H	L	L	L	L	L	
7	H	X	L	H	H	H	H	L	L	L	H	H	H	H	
8	H	X	H	L	L	L	H	L	L	L	L	L	L	L	
9	H	X	H	L	L	H	H	L	L	L	H	H	L	L	
10	H	X	H	L	H	L	H	H	H	H	L	L	H	L	
11	H	X	H	L	H	H	H	H	H	L	L	H	H	L	
12	H	X	H	H	L	L	H	H	L	H	H	H	L	L	
13	H	X	H	H	L	H	H	L	H	H	L	H	L	L	
14	H	X	H	H	H	L	H	H	H	H	L	L	L	L	
15	H	X	H	H	H	H	H	H	H	H	H	H	H	H	
\overline{BI}	X	X	X	X	X	X	L	H	H	H	H	H	H	H	2
\overline{RBI}	H	L	L	L	L	L	L	H	H	H	H	H	H	H	3
\overline{LT}	L	X	X	X	X	X	H	L	L	L	L	L	L	L	4

Note 1: $\overline{BI/RBO}$ is wire-AND logic serving as blanking input (\overline{BI}) and/or ripple-blanking output (\overline{RBO}). The blanking out (\overline{BI}) must be open or held at a HIGH level when output functions 0 through 15 are desired, and ripple-blanking input (\overline{RBI}) must be open or at a HIGH level if blanking or a decimal 0 is not desired. X = input may be HIGH or LOW.

Note 2: When a LOW level is applied to the blanking input (forced condition) all segment outputs go to a HIGH level regardless of the state of any other input condition.

Note 3: When ripple-blanking input (\overline{RBI}) and inputs A0, A1, A2 and A3 are LOW level, with the lamp test input at HIGH level, all segment outputs go to a HIGH level and the ripple-blanking output (\overline{RBO}) goes to a LOW level (response condition).

Note 4: When the blanking input/ripple-blanking output ($\overline{BI/RBO}$) is open or held at a HIGH level, and a LOW level is applied to lamp test input, all segment outputs go to a LOW level.

Physical Dimensions inches (millimeters)

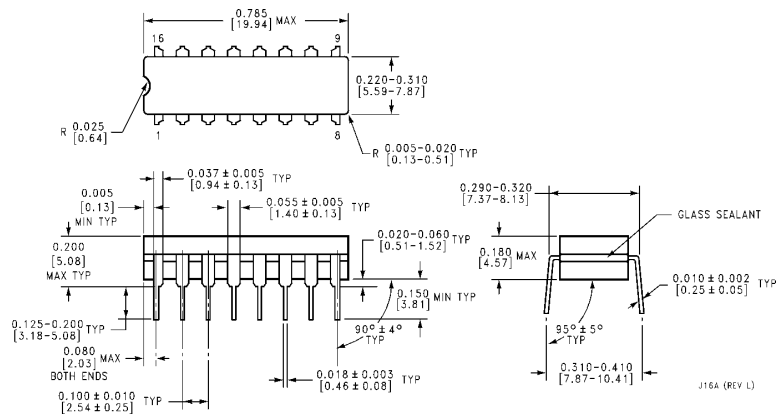

16-Lead Ceramic Dual-In-Line Package (J)
Order Number DM54LS47J
NS Package Number J16A

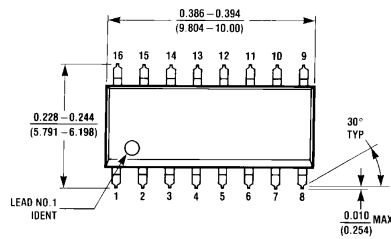

16-Lead Small Outline Molded Package (M)
Order Number DM74LS47M
NS Package Number M16A

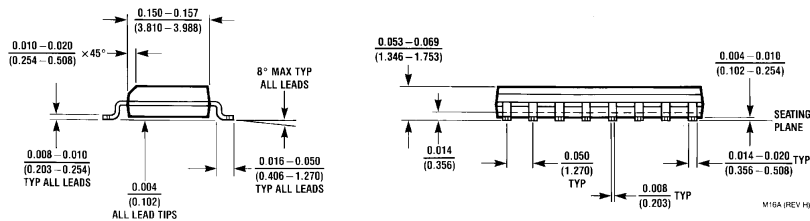

Physical Dimensions inches (millimeters) (Continued)

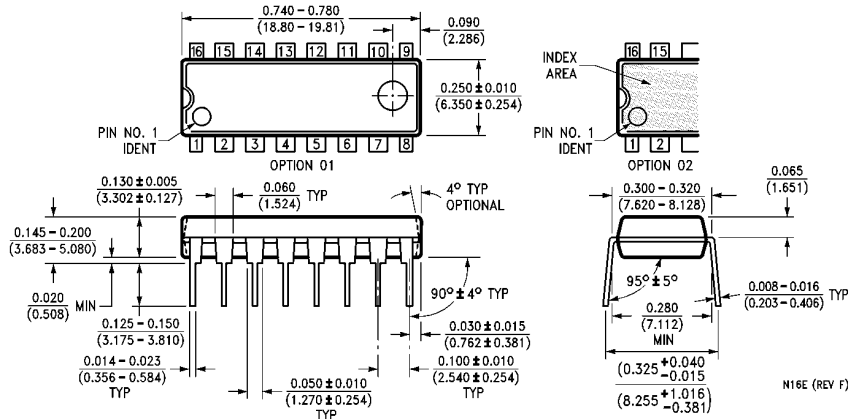

16-Lead Molded Dual-In-Line Package (N)
Order Number DM74LS47N
NS Package Number N16E

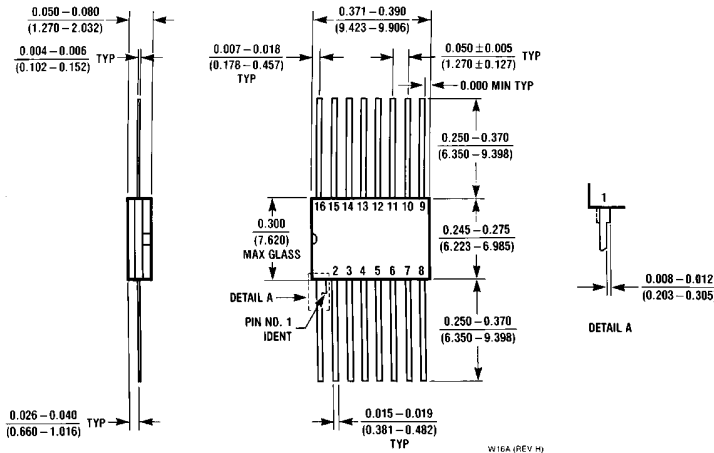

16-Lead Ceramic Flat Package (W)
Order Number DM54LS47W
NS Package Number W16A

LIFE SUPPORT POLICY

NATIONAL'S PRODUCTS ARE NOT AUTHORIZED FOR USE AS CRITICAL COMPONENTS IN LIFE SUPPORT DEVICES OR SYSTEMS WITHOUT THE EXPRESS WRITTEN APPROVAL OF THE PRESIDENT OF NATIONAL SEMICONDUCTOR CORPORATION. As used herein:

1. Life support devices or systems are devices or systems which, (a) are intended for surgical implant into the body, or (b) support or sustain life, and whose failure to perform, when properly used in accordance with instructions for use provided in the labeling, can be reasonably expected to result in a significant injury to the user.
2. A critical component is any component of a life support device or system whose failure to perform can be reasonably expected to cause the failure of the life support device or system, or to affect its safety or effectiveness.



National Semiconductor Corporation
 1111 West Bardin Road
 Arlington, TX 76017
 Tel: (800) 272-9959
 Fax: (1-800) 737-7018

National Semiconductor Europe
 Fax: (+49) 0-180-530 85 86
 Email: onjwge@tevm2.nsc.com
 Deutsch Tel: (+49) 0-180-530 85 85
 English Tel: (+49) 0-180-532 78 32
 Français Tel: (+49) 0-180-532 93 58
 Italiano Tel: (+49) 0-180-534 16 80

National Semiconductor Hong Kong Ltd.
 19th Floor, Straight Block,
 Ocean Centre, 5 Canton Rd.
 Tsimshatsui, Kowloon
 Hong Kong
 Tel: (852) 2737-1600
 Fax: (852) 2736-9960

National Semiconductor Japan Ltd.
 Tel: 81-043-299-2309
 Fax: 81-043-299-2408

National does not assume any responsibility for use of any circuitry described, no circuit patent licenses are implied and National reserves the right at any time without notice to change said circuitry and specifications.

This datasheet has been download from:

www.datasheetcatalog.com

Datasheets for electronics components.

National Semiconductor was acquired by Texas Instruments.

http://www.ti.com/corp/docs/investor_relations/pr_09_23_2011_national_semiconductor.html

This file is the datasheet for the following electronic components:

DM54LS47 - <http://www.ti.com/product/dm54ls47?HQS=TI-null-null-dscatalog-df-pf-null-ww>

DM74LS47 - <http://www.ti.com/product/dm74ls47?HQS=TI-null-null-dscatalog-df-pf-null-ww>