

DATA SHEET

74ALS373/74ALS374 Latch/flip-flop

Product specification
IC05 Data Handbook

1991 Feb 08

Latch/flip-flop

74ALS373/74ALS374

74ALS373 Octal transparent latch (3-State)

74ALS374 Octal D flip-flop (3-State)

FEATURES

- 8-bit transparent latch – 74ALS373
- 8-bit positive edge triggered register – 74ALS374
- 3-State output buffers
- Common 3-State output register
- Independent register and 3-State buffer operation

TYPE	TYPICAL PROPAGATION DELAY	TYPICAL SUPPLY CURRENT (TOTAL)
74ALS373	6.0ns	14mA

TYPE	TYPICAL f_{MAX}	TYPICAL SUPPLY CURRENT (TOTAL)
74ALS374	50MHz	17mA

ORDERING INFORMATION

DESCRIPTION	ORDER CODE	DRAWING NUMBER
	COMMERCIAL RANGE $V_{CC} = 5V \pm 10\%$, $T_{amb} = 0^{\circ}C$ to $+70^{\circ}C$	
20-pin plastic DIP	74ALS373N, 74ALS374N	SOT146-1
20-pin plastic SOL	74ALS373D, 74ALS374D	SOT163-1
20-pin plastic SSOP Type II	74ALS373DB, 74ALS374DB	SOT339-1

INPUT AND OUTPUT LOADING AND FAN-OUT TABLE

PINS	DESCRIPTION	74ALS (U.L.) HIGH/LOW	LOAD VALUE HIGH/LOW
D0 – D7	Data inputs	1.0/1.0	20 \times A/0.1mA
E (74ALS373)	Enable input (active-High)	1.0/1.0	20 \times A/0.1mA
\overline{OE}	Output enable inputs (active-Low)	1.0/1.0	20 \times A/0.1mA
CP (74ALS374)	Clock pulse input (active rising edge)	1.0/1.0	20 \times A/0.1mA
Q0 – Q7	3-State outputs	130/240	2.6mA/24mA

NOTE: One (1.0) ALS unit load is defined as: 20 \times A in the High state and 0.1mA in the Low state.

DESCRIPTION

The 74ALS373 is an octal transparent latch coupled to eight 3-State output devices. The two sections of the device are controlled independently by enable (E) and output enable (\overline{OE}) control gates.

The data on the D inputs is transferred to the latch outputs when the enable (E) input is High. The latch remains transparent to the data input while E is High, and stores the data that is present one setup time before the High-to-Low enable transition.

The 3-State output buffers are designed to drive heavily loaded 3-State buses, MOS memories, or MOS microprocessors.

The active-Low output enable (OE) controls all eight 3-State buffers independent of the latch operation. When OE is Low, latched or transparent data appears at the output.

When OE is High, the outputs are in High impedance "off" state, which means they will neither drive nor load the bus.

The 74ALS374 is an 8-bit edge triggered register coupled to eight 3-State output buffers. The two sections of the device are controlled independently by clock (CP) and output enable (OE) control gates.

The register is fully edge triggered. The state of the D input, one setup time before the Low-to-High clock transition is transferred to the corresponding flip-flop's Q output.

The 3-State output buffers are designed to drive heavily loaded 3-State buses, MOS memories, or MOS microprocessors.

The active-Low output enable (OE) controls all eight 3-State buffers independent of the register operation. When OE is Low, the data in the register appears at the outputs. When OE is High, the outputs are in High impedance "off" state, which means they will neither drive nor load the bus.

Latch/flip-flop

74ALS373/74ALS374

PIN CONFIGURATION – 74ALS373

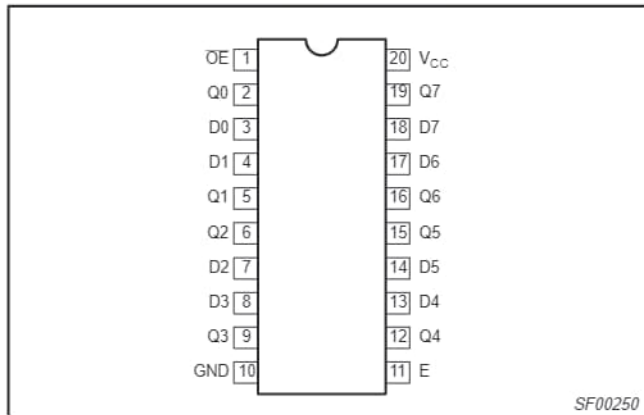

PIN CONFIGURATION – 74ALS374

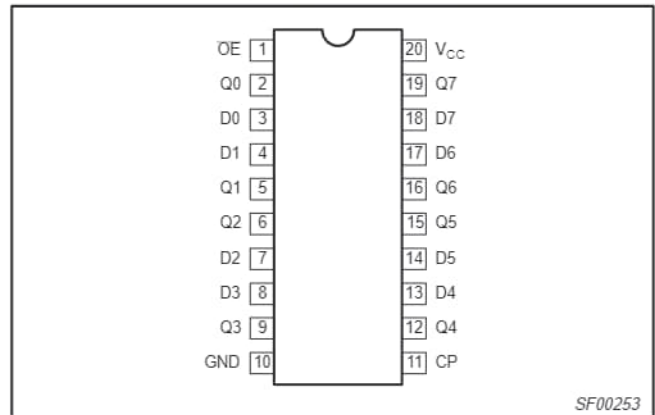

LOGIC SYMBOL – 74ALS373

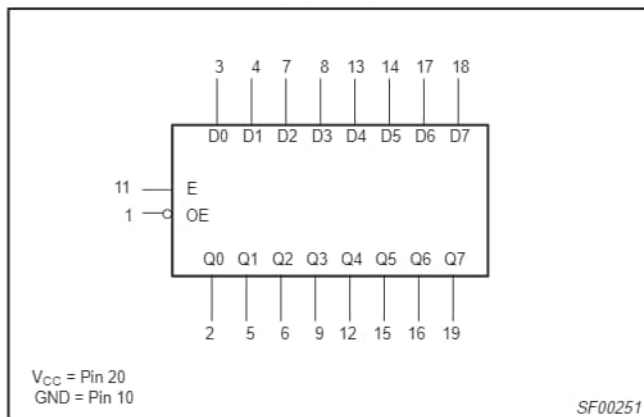

LOGIC SYMBOL – 74ALS374

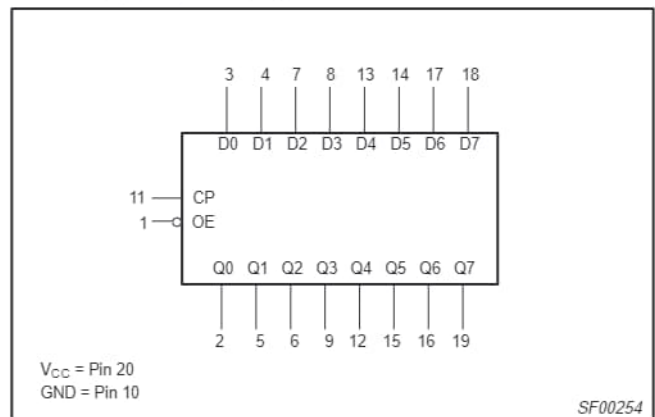

IEC/IEEE SYMBOL – 74ALS373

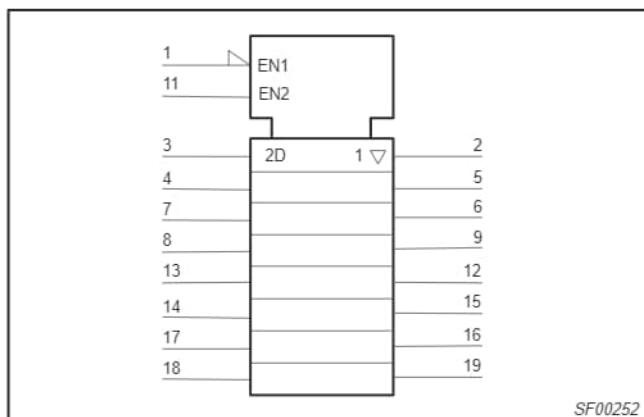

IEC/IEEE SYMBOL – 74ALS374

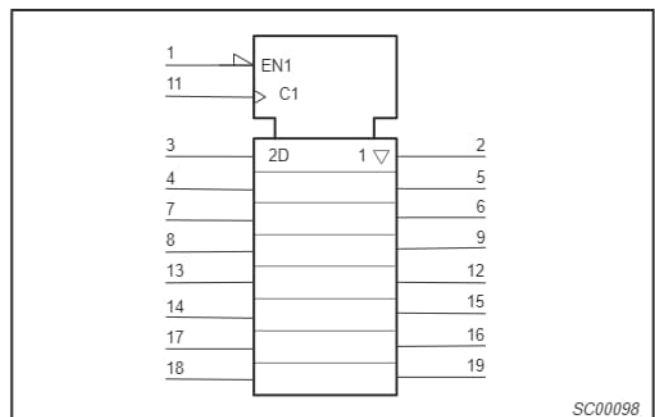

Latch/flip-flop

74ALS373/74ALS374

LOGIC DIAGRAM – 74ALS373

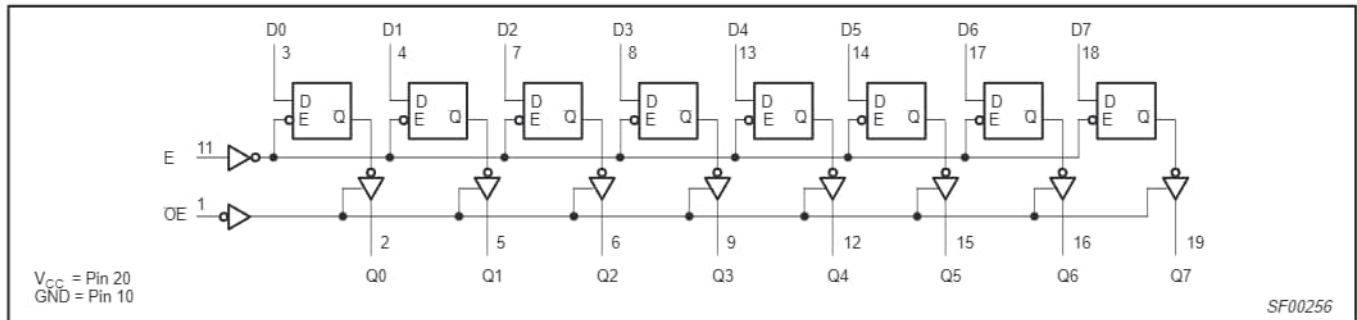

FUNCTION TABLE – 74ALS373

INPUTS			INTERNAL REGISTER	OUTPUTS	OPERATING MODE
\overline{OE}	E	D _n		Q0 – Q7	
L	H	L	L	L	Enable and read register
L	H	H	H	H	
L	↓	l	L	L	Latch and read register
L	↓	h	H	H	
L	L	X	NC	NC	Hold
H	L	X	NC	Z	Disable outputs
H	H	D _n	D _n	Z	

H = High-voltage level
 h = High state must be present one setup time before the High-to-Low enable transition
 L = Low-voltage level
 l = Low state must be present one setup time before the High-to-Low enable transition
 NC = No change
 X = Don't care
 Z = High impedance "off" state
 ↓ = High-to-Low enable transition

Latch/flip-flop

74ALS373/74ALS374

LOGIC DIAGRAM – 74ALS374

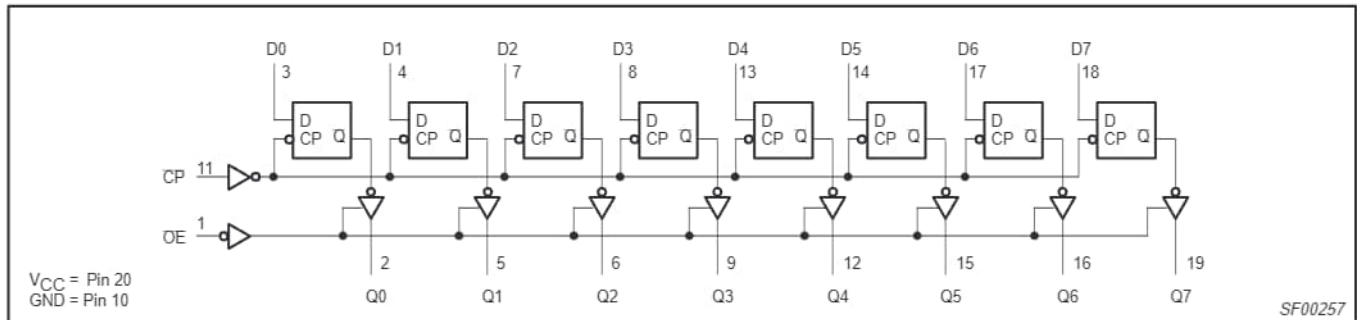

FUNCTION TABLE – 74ALS374

INPUTS			INTERNAL REGISTER	OUTPUTS	OPERATING MODE
\overline{OE}	CP	Dn		Q0 – Q7	
L	↑	l	L	L	Load and read register
L	↑	h	H	H	
L	↑	X	NC	NC	Hold
H	↑	X	NC	Z	Disable outputs
H	↑	Dn	Dn	Z	

H = High-voltage level
 h = High state must be present one setup time before the Low-to-High clock transition
 L = Low-voltage level
 l = Low state must be present one setup time before the Low-to-High clock transition
 NC = No change
 X = Don't care
 Z = High impedance "off" state
 ↑ = Low-to-High clock transition
 † = Not Low-to-High clock transition

ABSOLUTE MAXIMUM RATINGS

(Operation beyond the limit set forth in this table may impair the useful life of the device. Unless otherwise noted these limits are over the operating free-air temperature range.)

SYMBOL	PARAMETER	RATING	UNIT
V_{CC}	Supply voltage	-0.5 to +7.0	V
V_{IN}	Input voltage	-0.5 to +7.0	V
I_{IN}	Input current	-30 to +5	mA
V_{OUT}	Voltage applied to output in High output state	-0.5 to V_{CC}	V
I_{OUT}	Current applied to output in Low output state	48	mA
T_{amb}	Operating free-air temperature range	0 to +70	°C
T_{stg}	Storage temperature range	-65 to +150	°C

Latch/flip-flop

74ALS373/74ALS374

RECOMMENDED OPERATING CONDITIONS

SYMBOL	PARAMETER	LIMITS			UNIT
		MIN	NOM	MAX	
V_{CC}	Supply voltage	4.5	5.0	5.5	V
V_{IH}	High-level input voltage	2.0			V
V_{IL}	Low-level input voltage			0.8	V
I_{IK}	Input clamp current			-18	mA
I_{OH}	High-level output current			-2.6	mA
I_{OL}	Low-level output current			24	mA
T_{amb}	Operating free-air temperature range	0		+70	°C

DC ELECTRICAL CHARACTERISTICS

(Over recommended operating free-air temperature range unless otherwise noted.)

SYMBOL	PARAMETER		TEST CONDITIONS ¹	LIMITS			UNIT	
				MIN	TYP ²	MAX		
V_{OH}	High-level output voltage		$V_{CC} = \pm 10\%$, $V_{IL} = \text{MAX}$, $V_{IH} = \text{MIN}$	$I_{OH} = -0.4\text{mA}$	$V_{CC} - 2$		V	
				$I_{OH} = \text{MAX}$	2.4	3.2	V	
V_{OL}	Low-level output voltage		$V_{CC} = \text{MIN}$, $V_{IL} = \text{MAX}$, $V_{IH} = \text{MIN}$	$I_{OL} = 12\text{mA}$		0.25	0.40	V
				$I_{OL} = 24\text{mA}$		0.35	0.50	V
V_{IK}	Input clamp voltage		$V_{CC} = \text{MIN}$, $I_I = I_{IK}$		-0.73	-1.2	V	
I_I	Input current at maximum input voltage		$V_{CC} = \text{MAX}$, $V_I = 7.0\text{V}$			0.1	mA	
I_{IH}	High-level input current		$V_{CC} = \text{MAX}$, $V_I = 2.7\text{V}$			20	μA	
I_{IL}	Low-level input current	74ALS373	$V_{CC} = \text{MAX}$, $V_I = 0.4\text{V}$			-0.1	mA	
		74ALS374				-0.2	mA	
I_{OZH}	Off-state output current, High-level voltage applied		$V_{CC} = \text{MAX}$, $V_I = 2.7\text{V}$			20	μA	
I_{OZL}	Off-state output current, Low-level voltage applied		$V_{CC} = \text{MAX}$, $V_I = 0.4\text{V}$			-20	μA	
I_O	Output current ³		$V_{CC} = \text{MAX}$, $V_O = 2.25\text{V}$	-30		-112	mA	
I_{CC}	Supply current (total)		74ALS373	I_{CCH}	$V_{CC} = \text{MAX}$	7	16	mA
				I_{CCL}		14	25	mA
				I_{CCZ}		17	27	mA
			74ALS374	I_{CCH}		11	19	mA
				I_{CCL}		19	29	mA
				I_{CCZ}		20	31	mA

NOTES:

- For conditions shown as MIN or MAX, use the appropriate value specified under recommended operating conditions for the applicable type.
- All typical values are at $V_{CC} = 5\text{V}$, $T_{amb} = 25^\circ\text{C}$.
- The output conditions have been chosen to produce a current that closely approximates one half of the true short-circuit output current, I_{OS} .

Latch/flip-flop

74ALS373/74ALS374

AC ELECTRICAL CHARACTERISTICS

SYMBOL	PARAMETER	TEST CONDITION	LIMITS		UNIT	
			$T_{amb} = 0^{\circ}\text{C to } +70^{\circ}\text{C}$ $V_{CC} = +5.0\text{V} \pm 10\%$ $C_L = 50\text{pF}, R_L = 500\Omega$			
			MIN	MAX		
t_{PLH} t_{PHL}	Propagation delay Dn to Qn	74ALS373	Waveform 3	2.0 2.0	12.0 14.0	ns
t_{PLH} t_{PHL}	Propagation delay E to Qn		Waveform 2	3.0 3.0	14.0 14.0	ns
t_{PZH} t_{PZL}	Output enable time to High or Low level		Waveform 6 Waveform 7	2.0 3.0	14.0 14.0	ns
t_{PHZ} t_{PLZ}	Output disable time from High or Low level		Waveform 6 Waveform 7	2.0 2.0	10.0 12.0	ns
f_{MAX}	Maximum clock frequency	74ALS374	Waveform 1	50		MHz
t_{PLH} t_{PHL}	Propagation delay CP to Qn		Waveform 1	3.0 4.0	12.0 14.0	ns
t_{PZH} t_{PZL}	Output enable time to High or Low level		Waveform 6 Waveform 7	3.0 3.0	9.0 11.0	ns
t_{PHZ} t_{PLZ}	Output disable time from High or Low level		Waveform 6 Waveform 7	2.0 3.0	10.0 12.0	ns

AC SETUP REQUIREMENTS

SYMBOL	PARAMETER	TEST CONDITION	LIMITS		UNIT	
			$T_{amb} = 0^{\circ}\text{C to } +70^{\circ}\text{C}$ $V_{CC} = +5.0\text{V} \pm 10\%$ $C_L = 50\text{pF}, R_L = 500\Omega$			
			MIN	MAX		
$t_{SU(H)}$ $t_{SU(L)}$	Setup time, High or Low Dn to E	74ALS373	Waveform 4	6.0 6.0		ns
$t_H(H)$ $t_H(L)$	Hold time, High or Low Dn to E		Waveform 4	6.0 6.0		ns
$t_W(H)$	E Pulse width, High		Waveform 2	10.0		ns
$t_{SU(H)}$ $t_{SU(L)}$	Setup time, High or Low Dn to CP	74ALS374	Waveform 5	6.0 6.0		ns
$t_H(H)$ $t_H(L)$	Hold time, High or Low Dn to CP		Waveform 5	1.0 1.0		ns
$t_W(H)$ $t_W(L)$	CP Pulse width, High or Low		Waveform 1	10.0 10.0		ns

Latch/flip-flop

74ALS373/74ALS374

AC WAVEFORMS

For all waveforms, $V_M = 1.3V$.

The shaded areas indicate when the input is permitted to change for predictable output performance.

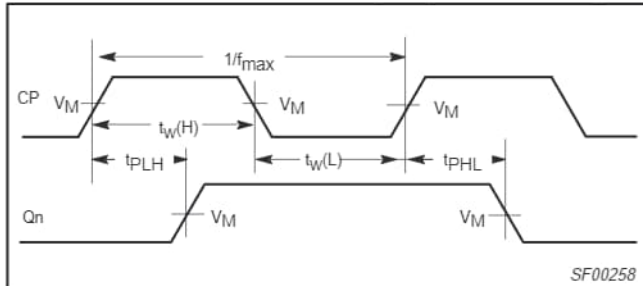

Waveform 1. Propagation Delay for Clock Input to Output, Clock Pulse Widths, and Maximum Clock Frequency

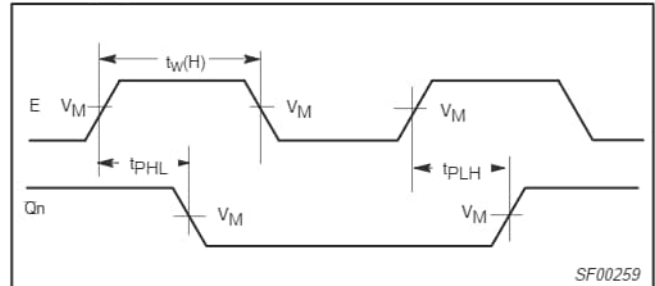

Waveform 2. Propagation Delay for Enable to Output and Enable Pulse Width

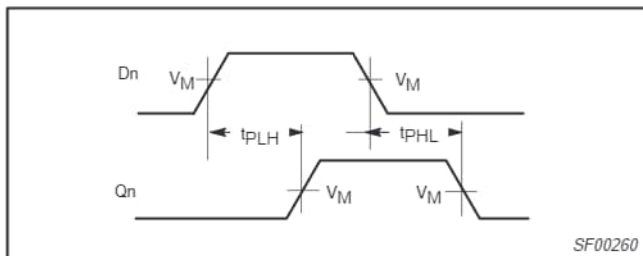

Waveform 3. Propagation Delay for Data to Output

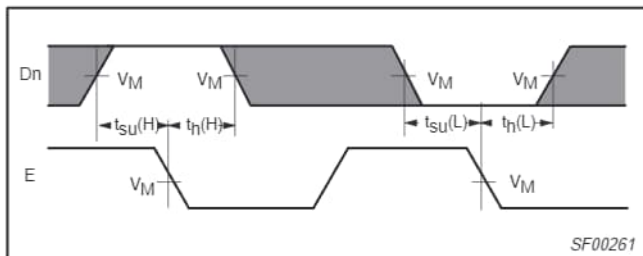

Waveform 4. Data Setup Time and Hold Times

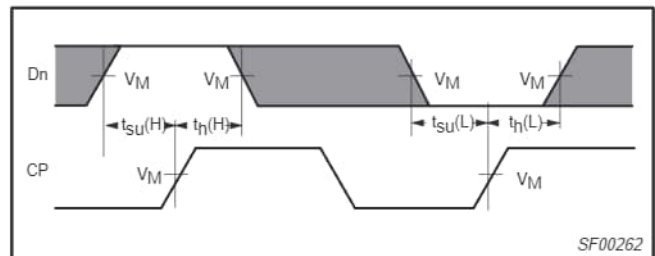

Waveform 5. Data Setup Time and Hold Times

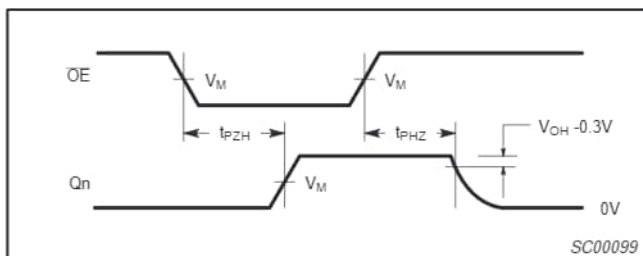

Waveform 6. 3-State Output Enable Time to High Level and Output Disable Time from High Level

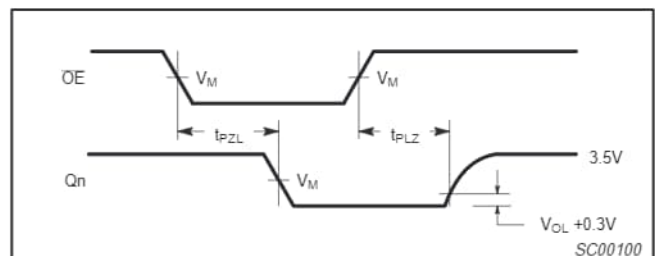

Waveform 7. 3-State Output Enable Time to Low Level and Output Disable Time from Low Level

Latch/flip-flop

74ALS373/74ALS374

TEST CIRCUIT AND WAVEFORMS

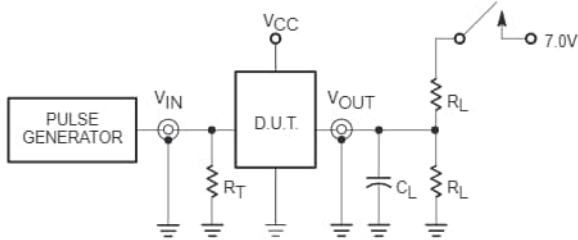

Test Circuit for 3-State Outputs

SWITCH POSITION

TEST	SWITCH
t_{PLZ}, t_{PZL}	closed
All other	open

DEFINITIONS:

- R_L = Load resistor; see AC electrical characteristics for value.
- C_L = Load capacitance includes jig and probe capacitance; see AC electrical characteristics for value.
- R_T = Termination resistance should be equal to Z_{OUT} of pulse generators.

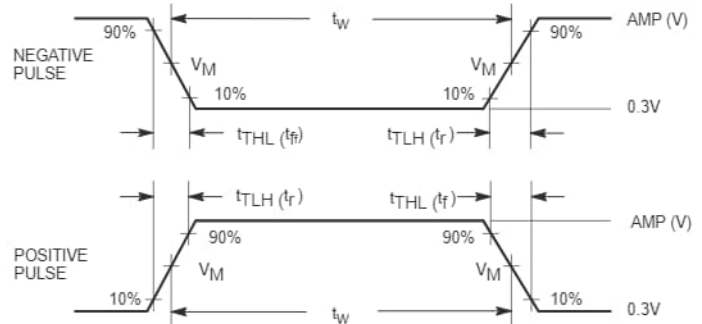

Input Pulse Definition

Family	INPUT PULSE REQUIREMENTS					
	Amplitude	V_M	Rep.Rate	t_w	t_{TLH}	t_{THL}
74ALS	3.5V	1.3V	1MHz	500ns	2.0ns	2.0ns

SC00072

Latch/flip-flop

74ALS373/74ALS374

DIP20: plastic dual in-line package; 20 leads (300 mil)

SOT146-1

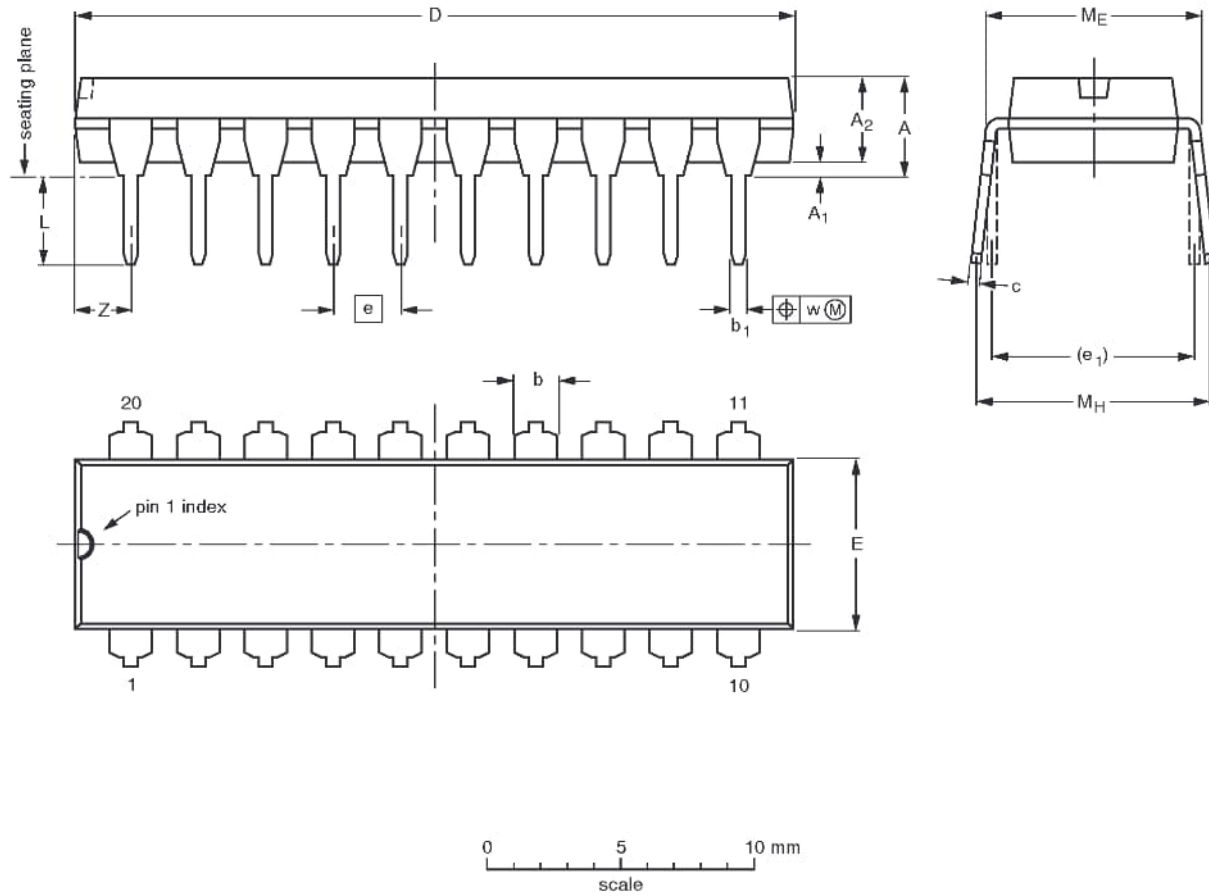

DIMENSIONS (inch dimensions are derived from the original mm dimensions)

UNIT	A max.	A ₁ min.	A ₂ max.	b	b ₁	c	D ⁽¹⁾	E ⁽¹⁾	e	e ₁	L	M _E	M _H	w	Z ⁽¹⁾ max.
mm	4.2	0.51	3.2	1.73 1.30	0.53 0.38	0.36 0.23	26.92 26.54	6.40 6.22	2.54	7.62	3.60 3.05	8.25 7.80	10.0 8.3	0.254	2.0
inches	0.17	0.020	0.13	0.068 0.051	0.021 0.015	0.014 0.009	1.060 1.045	0.25 0.24	0.10	0.30	0.14 0.12	0.32 0.31	0.39 0.33	0.01	0.078

Note

1. Plastic or metal protrusions of 0.25 mm maximum per side are not included.

OUTLINE VERSION	REFERENCES				EUROPEAN PROJECTION	ISSUE DATE
	IEC	JEDEC	EIAJ			
SOT146-1			SC603			-92-11-17 95-05-24

Latch/flip-flop

74ALS373/74ALS374

SO20: plastic small outline package; 20 leads; body width 7.5 mm

SOT163-1

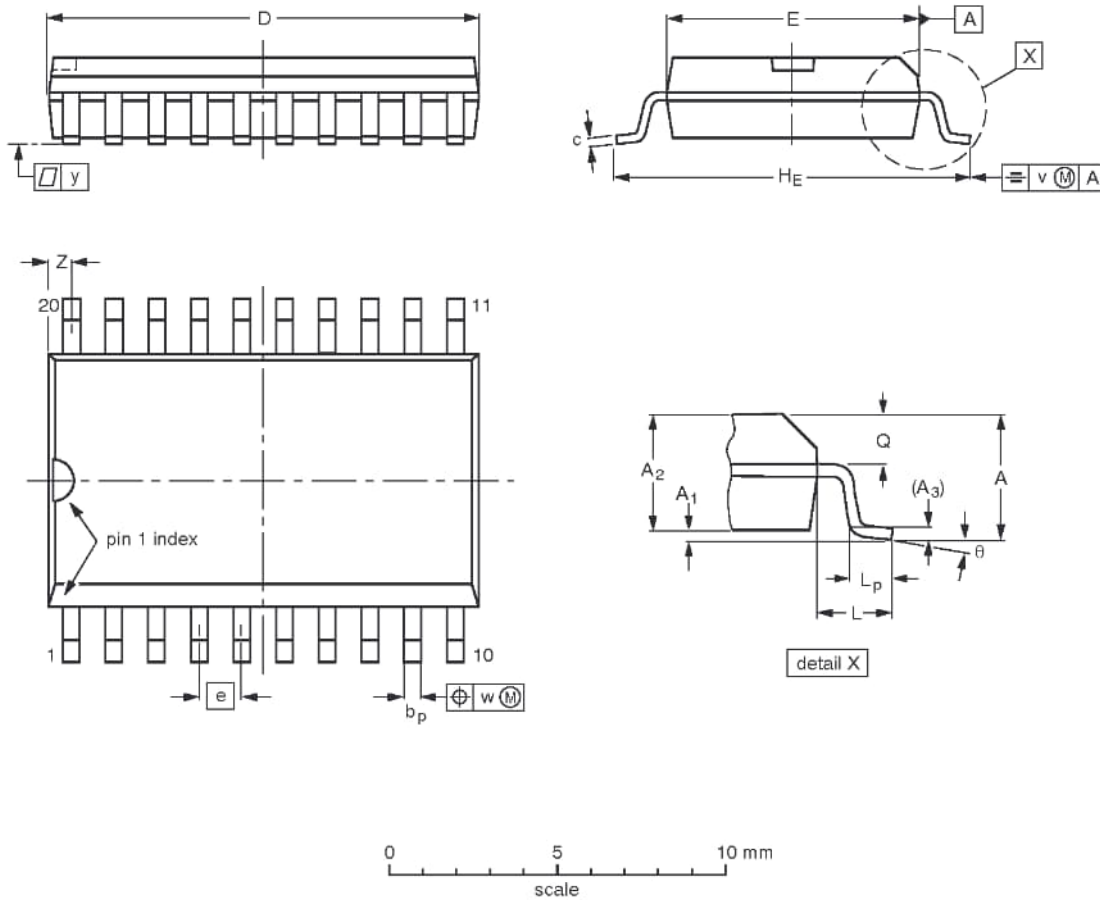

DIMENSIONS (inch dimensions are derived from the original mm dimensions)

UNIT	A max.	A ₁	A ₂	A ₃	b _p	c	D ⁽¹⁾	E ⁽¹⁾	e	H _E	L	L _p	Q	v	w	y	Z ⁽¹⁾	θ
mm	2.65	0.30 0.10	2.45 2.25	0.25	0.49 0.36	0.32 0.23	13.0 12.6	7.6 7.4	1.27	10.65 10.00	1.4	1.1 0.4	1.1 1.0	0.25	0.25	0.1	0.9 0.4	8° 0°
inches	0.10	0.012 0.004	0.096 0.089	0.01	0.019 0.014	0.013 0.009	0.51 0.49	0.30 0.29	0.050	0.42 0.39	0.055	0.043 0.016	0.043 0.039	0.01	0.01	0.004	0.035 0.016	

Note

1. Plastic or metal protrusions of 0.15 mm maximum per side are not included.

OUTLINE VERSION	REFERENCES				EUROPEAN PROJECTION	ISSUE DATE
	IEC	JEDEC	EIAJ			
SOT163-1	075E04	MS-013AC				-92-11-17 95-01-24

Latch/flip-flop

74ALS373/74ALS374

SSOP20: plastic shrink small outline package; 20 leads; body width 5.3 mm

SOT339-1

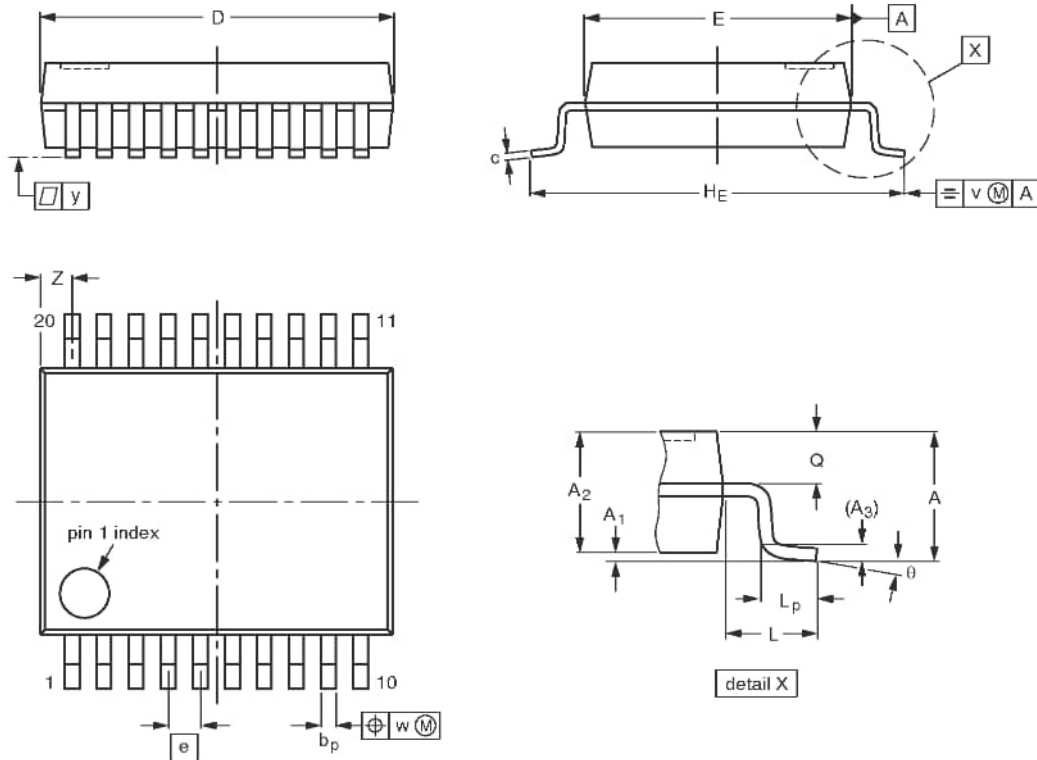

DIMENSIONS (mm are the original dimensions)

UNIT	A max.	A ₁	A ₂	A ₃	b _p	c	D ⁽¹⁾	E ⁽¹⁾	e	H _E	L	L _p	Q	v	w	y	z ⁽¹⁾	θ
mm	2.0	0.21 0.05	1.80 1.65	0.25	0.38 0.25	0.20 0.09	7.4 7.0	5.4 5.2	0.65	7.9 7.6	1.25	1.03 0.63	0.9 0.7	0.2	0.13	0.1	0.9 0.5	8° 0°

Note

1. Plastic or metal protrusions of 0.20 mm maximum per side are not included.

OUTLINE VERSION	REFERENCES				EUROPEAN PROJECTION	ISSUE DATE
	IEC	JEDEC	EIAJ			
SOT339-1		MO-150AE				-93-09-08 95-02-04

Latch/flip-flop

74ALS373/74ALS374

DEFINITIONS

Data Sheet Identification	Product Status	Definition
<i>Objective Specification</i>	Formative or in Design	This data sheet contains the design target or goal specifications for product development. Specifications may change in any manner without notice.
<i>Preliminary Specification</i>	Preproduction Product	This data sheet contains preliminary data, and supplementary data will be published at a later date. Philips Semiconductors reserves the right to make changes at any time without notice in order to improve design and supply the best possible product.
<i>Product Specification</i>	Full Production	This data sheet contains Final Specifications. Philips Semiconductors reserves the right to make changes at any time without notice, in order to improve design and supply the best possible product.

Philips Semiconductors and Philips Electronics North America Corporation reserve the right to make changes, without notice, in the products, including circuits, standard cells, and/or software, described or contained herein in order to improve design and/or performance. Philips Semiconductors assumes no responsibility or liability for the use of any of these products, conveys no license or title under any patent, copyright, or mask work right to these products, and makes no representations or warranties that these products are free from patent, copyright, or mask work right infringement, unless otherwise specified. Applications that are described herein for any of these products are for illustrative purposes only. Philips Semiconductors makes no representation or warranty that such applications will be suitable for the specified use without further testing or modification.

LIFE SUPPORT APPLICATIONS

Philips Semiconductors and Philips Electronics North America Corporation Products are not designed for use in life support appliances, devices, or systems where malfunction of a Philips Semiconductors and Philips Electronics North America Corporation Product can reasonably be expected to result in a personal injury. Philips Semiconductors and Philips Electronics North America Corporation customers using or selling Philips Semiconductors and Philips Electronics North America Corporation Products for use in such applications do so at their own risk and agree to fully indemnify Philips Semiconductors and Philips Electronics North America Corporation for any damages resulting from such improper use or sale.

Philips Semiconductors
 811 East Arques Avenue
 P.O. Box 3409
 Sunnyvale, California 94088-3409
 Telephone 800-234-7381

▼ Copyright Philips Electronics North America Corporation 1997
 All rights reserved. Printed in U.S.A.

Let's make things better.