



## **Description**

The PT2249A / PT2250A Series are infra-red remote control receivers utilizing CMOS Technology. Remote Control System can be constructed together with the PT2248 remote control encoder. The PT2249A Series are packaged in 16 pins DIP (PT2249A version is also available in SOP package) and are capable of controlling 10 functions while the PT2250A Series are packaged in 24 pins DIP and are capable of controlling 18 functions. Several options, inverting/non-inverting IR signal input and/or dependent/independent cyclic (toggle) outputs, are provided to fit different application needs.

## **Features**

- CMOS Technology
- Low Power Consumption
- Very High Noise Immunity
- Able to output parallel multiple keying signals sent from the transmitter (PT2249A is able to output up to 5 functions simultaneously while PT2250A is able to output up to 6 functions simultaneously)
- Outputs for single pulse, hold pulse and cyclic pulse are provided
- A single terminal type oscillator by means of RC is provided
- Code Detection Circuit prevents interference from various types of machines and apparatus
- Digital Filtering and Code Checking prevent interference from light sources such as PL Lamp without sacrificing the receiving sensitivity

## **Applications**

- Audio Equipment Remote Control
- Television (TV) Remote Control
- Video Cassette Recorder (VCR) Remote Control



Remote Control Receiver IC

PT2249A & PT2250A Series

Pin Configurations

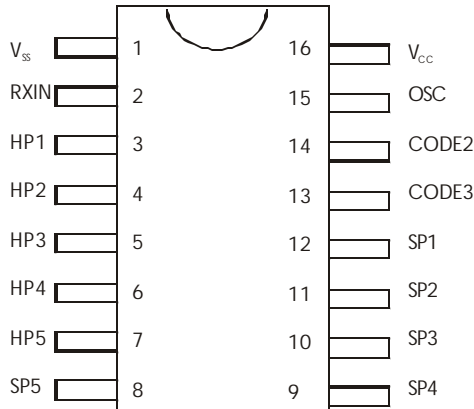

PT2249A (16 PDIP 300 mil)  
PT2249A-SN (16 SOP 150 mil)

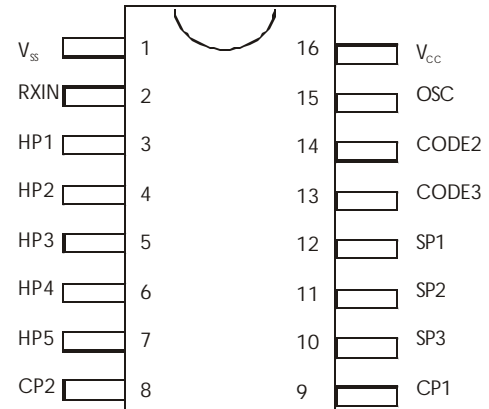

(16 PDIP 300 mil)

PT2249AI / PT2249AIN  
PT2249AL / PT2249ALN  
PT2249AH / PT2249AHN

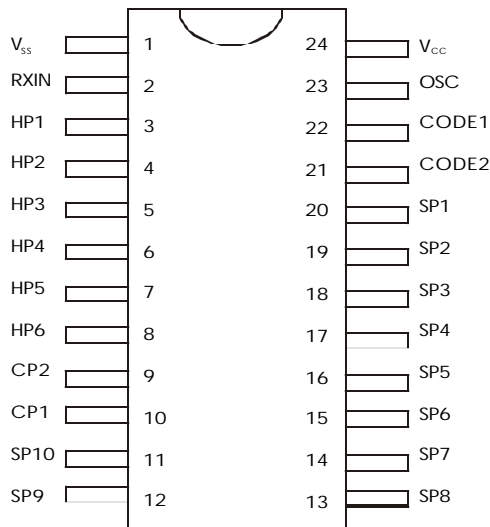

(24 PDIP 600 mil)

PT2250A / PT2250AN  
PT2250AL / PT2250ALN

**A** - Advanced Version  
**N** - Inversed RXIN Input  
**I** - Independent Cyclic (Toggle) Outputs  
**L** - Advanced Dependent Cyclic (Toggle) Outputs  
**H** - Output Format same as "L", except that when HP1 or HP2 is active, it will clear CP1.



Remote Control Receiver IC

PT2249A & PT2250A Series

Application Circuit

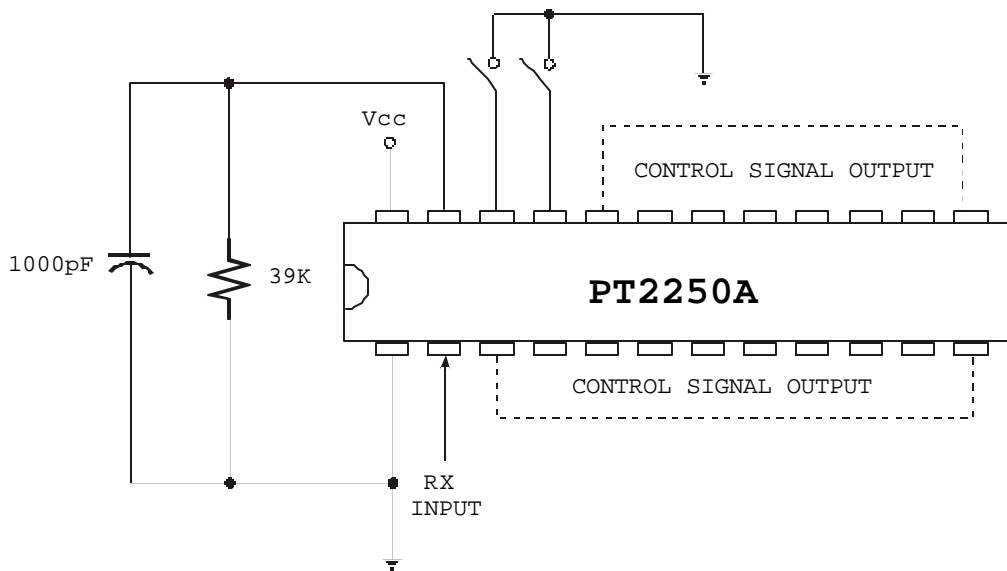
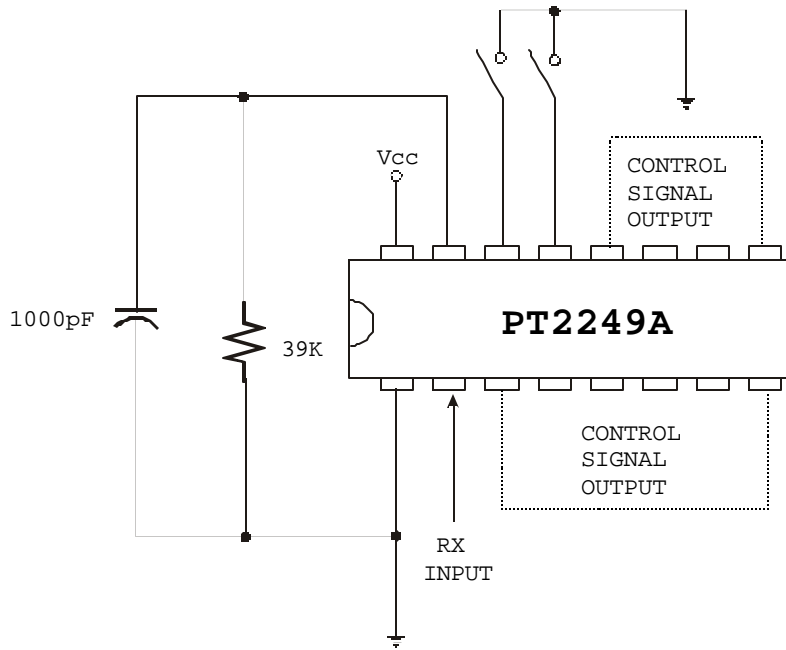



Remote Control Receiver IC

PT2249A & PT2250A Series

**Application Note:**

1. Combination of PT2248/PT2249A Series Code Bits

- a) PT2249A Series Code Bit C1 is internally pulled high and thereby set at a default value of “1”. Thus, PT2248 Code Bit C1 must be set at “1”.
- b) PT2249A Series Code Bits C2 and C3 may be programmed as follows:
  - 1) “0”, “0” (This combination is not available with TC9149.)
  - 2) “0”, “1”
  - 3) “1”, “0”
  - 4) “1”, “1”
- c) To set Code Bit to “1” on PT2248, diodes must be connected to Code Terminal from the T1 ~ T3 terminals.
- d) To set Code Bit to “0” on PT2248, the terminals must be kept floating, except C1 - add one diode.
- e) The Code Bits Combinations of PT2248 and PT2249A Series are shown below:

PT2248			PT2249A Series	
C1	C2	C3	C2	C3
1	0	0	0	0
1	0	1	0	1
1	1	0	1	0
1	1	1	1	1

- f) Example : (Refer to Example 1 diagram)

The following example shows the case when PT2248 Code Bits C1 = 1, C2 = 1, and C3 = 0. The CODE2 Pin of the PT2249A Series is programmed in floating state and CODE3 pin is connected to Vss (C2 = 1, C3 = 0. ) In this way, the PT2249A Series can match the C2, C3 Code Bits of PT2248 and correctly decode the remote commands.



Remote Control Receiver IC

PT2249A & PT2250A Series

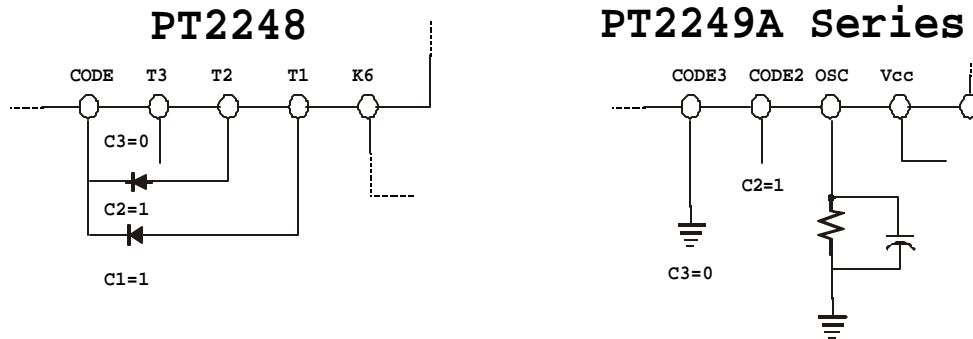

Example 1  
Circuit Diagram when Code Bit C2 = 1 and C3 = 0

2. Combination of PT2248/PT2250A Series Code Bits

- a) PT2250A Series Code Bit C3 is internally pulled high and thereby set at a default value of "1". Thus, PT2248 Code Bit C3 must be set at "1".
- b) PT2250A Series Code Bits C2 and C3 may be programmed as follows:
  - 1) "0", "0" (This combination is not available with TC9150.)
  - 2) "0", "1"
  - 3) "1", "0"
  - 4) "1", "1"
- c) To set Code Bit to "1" on PT2248, diodes must be connected to Code Terminal from the T1 ~ T3 terminals.
- d) To set Code Bit to "0" on PT2248, the terminals must be kept floating.
- e) The Code Bits Combinations of PT2248 and PT2250A Series are shown below:

PT2248			PT2250A Series	
C1	C2	C3	C1	C2
0	0	1	0	0
0	1	1	0	1
1	0	1	1	0
1	1	1	1	1



Remote Control Receiver IC

PT2249A & PT2250A Series

f) Example : (Refer to Example 2 diagram)

The following example shows the case when PT2248 Code Bits C1 = 0, C2 = 0, and C3 = 1. The CODE1 and CODE2 pins of the PT2250A Series are connected to the Vss (C1=0 and C2=0). In this way, the PT2250A or any of its series matches the C1 and C2 Code Bits of PT2248; thus, the remote commands are correctly decoded.

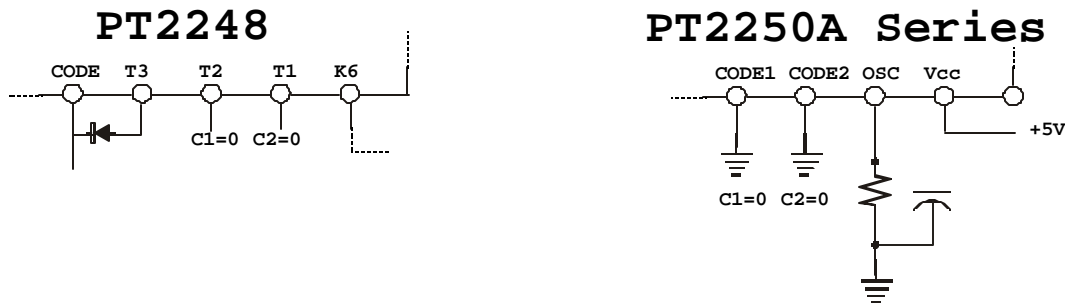

Example 2  
Circuit Diagram when Code Bit C1= 0 and C2 =