



9N90

Power MOSFET

**9A, 900V N-CHANNEL
POWER MOSFET**

■ **DESCRIPTION**

The UTC **9N90** uses UTC's advanced proprietary, planar stripe, DMOS technology to provide excellent $R_{DS(ON)}$, low gate charge and operation with low gate voltages. This device is suitable for use as a load switch or in PWM applications.

■ **FEATURES**

- * $R_{DS(ON)} = 1.4\Omega @V_{GS} = 10V$
- * Ultra Low Gate Charge (Typical 45 nC)
- * Low Reverse Transfer Capacitance (CRSS = Typical 14 pF)
- * Fast Switching Capability
- * Avalanche Energy Specified
- * Improved dv/dt Capability, High Ruggedness

■ **SYMBOL**

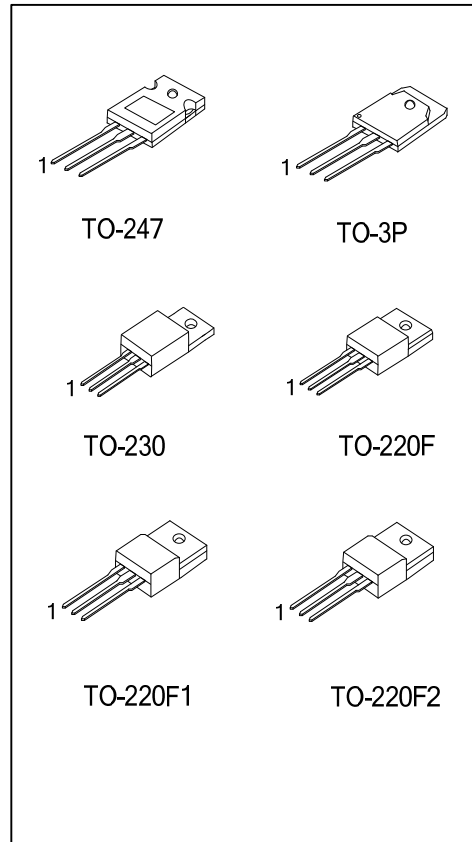
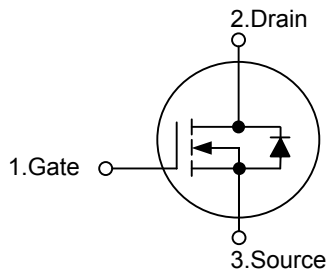

■ **ORDERING INFORMATION**

Ordering Number		Package	Pin Assignment			Packing
Lead Free	Halogen Free		1	2	3	
9N90L-T47-T	9N90G-T47-T	TO-247	G	D	S	Tube
9N90L-T3P-T	9N90G-T3P-T	TO-3P	G	D	S	Tube
9N90L-TC3-T	9N90G-TC3-T	TO-230	G	D	S	Tube
9N90L-TF1-T	9N90G-TF1-T	TO-220F1	G	D	S	Tube
9N90L-TF2-T	9N90G-TF2-T	TO-220F2	G	D	S	Tube
9N90L-TF3-T	9N90G-TF3-T	TO-220F	G	D	S	Tube

<p>9N90L-T47-T</p> <p>(1)Packing Type (2)Package Type (3)Lead Free</p>	<p>(1) T: Tube (2) T47: TO-247, T3P: TO-3P, TF1: TO-220F1, TF2: TO-220F2, TF3:TO-220F, TC3: TO-230 (3) G: Halogen Free, L: Lead Free</p>
--	--

■ ABSOLUTE MAXIMUM RATING ($T_C = 25^\circ\text{C}$, unless otherwise specified)

PARAMETER		SYMBOL	RATINGS	UNIT
Drain-Source Voltage		V_{DSS}	900	V
Gate-Source Voltage		V_{GSS}	± 30	V
Continuous Drain Current ($T_C = 25^\circ\text{C}$)		I_D	9.0	A
Pulsed Drain Current (Note 2)		I_{DM}	36	A
Avalanche Current (Note 2)		I_{AR}	9.0	A
Avalanche Energy	Single Pulsed(Note 3)	E_{AS}	900	mJ
	Repetitive(Note 2)	E_{AR}	28	mJ
Peak Diode Recovery dv/dt (Note 4)		dv/dt	4.0	V/ns
Power Dissipation	TO-247	P_D	160	W
	TO-3P		240	
	TO-230		147	
	TO-220F/TO-220F1		56	
	TO-220F2		58	
Linear Derating Factor above $T_C = 25^\circ\text{C}$	TO-247		1.28	W/ $^\circ\text{C}$
	TO-3P		1.92	
	TO-230		1.176	
	TO-220F/TO-220F1		0.448	
	TO-220F2		0.464	
Junction Temperature		T_J	150	$^\circ\text{C}$
Storage Temperature		T_{STG}	-55 ~ +150	$^\circ\text{C}$

Note: 1. Absolute maximum ratings are those values beyond which the device could be permanently damaged.

Absolute maximum ratings are stress ratings only and functional device operation is not implied.

2. Repetitive Rating : Pulse width limited by maximum junction temperature

3. $L = 21\text{mH}$, $I_{AS} = 9.0\text{A}$, $V_{DD} = 50\text{V}$, $R_G = 25\ \Omega$, Starting $T_J = 25^\circ\text{C}$

4. $I_{SD} \leq 9.0\text{A}$, $di/dt \leq 200\text{A}/\mu\text{s}$, $V_{DD} \leq BV_{DSS}$, Starting $T_J = 25^\circ\text{C}$

■ THERMAL DATA

PARAMETER		SYMBOL	RATINGS	UNIT
Junction to Ambient	TO-247	θ_{JA}	50	$^\circ\text{C}/\text{W}$
	TO-3P		40	
	TO-220F1/ TO-220F		62.5	
	TO-220F2/TO-230			
Junction to Case	TO-247	θ_{JC}	0.78	$^\circ\text{C}/\text{W}$
	TO-3P		0.52	
	TO-230		0.85	
	TO-220F/TO-220F1		2.25	
	TO-220F2		2.15	

■ ELECTRICAL CHARACTERISTICS (T_J=25°C, unless otherwise specified)

PARAMETER	SYMBOL	TEST CONDITIONS	MIN	TYP	MAX	UNIT
OFF CHARACTERISTICS						
Drain-Source Breakdown Voltage	BV _{DSS}	V _{GS} = 0 V, I _D = 250μA	900			V
Drain-Source Leakage Current	I _{DSS}	V _{DS} = 900 V, V _{GS} = 0 V			10	μA
Gate-Body Leakage Current	Forward	I _{GSSF}	V _{GS} = 30 V, V _{DS} = 0 V		100	nA
	Reverse	I _{GSSR}	V _{GS} = -30 V, V _{DS} = 0 V		-100	nA
Breakdown Voltage Temperature Coefficient	ΔBV _{DSS} /ΔT _J	I _D =250μA, Referenced to 25°C		0.99		V/°C
ON CHARACTERISTICS						
Gate Threshold Voltage	V _{GS(TH)}	V _{DS} = V _{GS} , I _D = 250μA	3.0		5.0	V
Static Drain-Source On-Resistance	R _{DS(ON)}	V _{GS} = 10V, I _D = 4.5A		1.05	1.4	Ω
DYNAMIC PARAMETERS						
Input Capacitance	C _{ISS}	V _{DS} = 25 V, V _{GS} = 0 V, f = 1.0 MHz		2100	2730	pF
Output Capacitance	C _{OSS}			175	230	pF
Reverse Transfer Capacitance	C _{RSS}			14	18	pF
SWITCHING CHARACTERISTICS						
Turn-On Delay Time	t _{D(ON)}	V _{DD} = 450V, I _D = 11.0 A, R _G = 25Ω (Note 1, 2)		50	110	ns
Turn-On Rise Time	t _R			120	250	ns
Turn-Off Delay Time	t _{D(OFF)}			100	210	ns
Turn-Off Fall Time	t _F			75	160	ns
Total Gate Charge	Q _G	V _{DS} = 720V, I _D = 11.0A, V _{GS} = 10 V (Note 1,2)		45	58	nC
Gate-Source Charge	Q _{GS}			13		nC
Gate-Drain Charge	Q _{GD}			18		nC
DRAIN-SOURCE DIODE CHARACTERISTICS AND MAXIMUM RATINGS						
Drain-Source Diode Forward Voltage	V _{SD}	V _{GS} = 0 V, I _S = 9.0 A			1.4	V
Maximum Continuous Drain-Source Diode Forward Current	I _S				9.0	A
Maximum Pulsed Drain-Source Diode Forward Current	I _{SM}				36	A
Reverse Recovery Time	t _{rr}	V _{GS} = 0 V, I _S = 9.0 A,		550		ns
Reverse Recovery Charge	Q _{RR}	dI _F / dt = 100 A/μs (Note 1)		6.5		μC

Notes: 1. Pulse Test : Pulse width ≤ 300μs, Duty cycles ≤ 2%

2. Essentially independent of operating temperature

■ TEST CIRCUITS AND WAVEFORMS(Cont.)

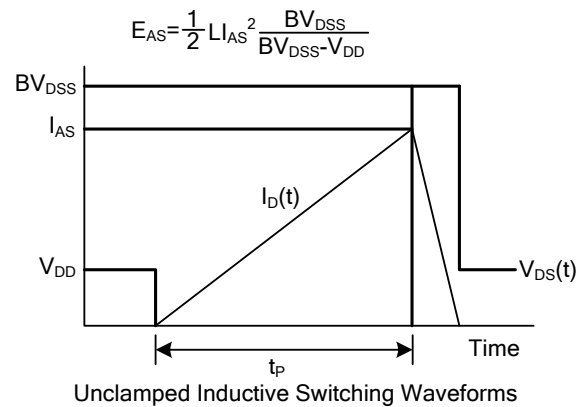
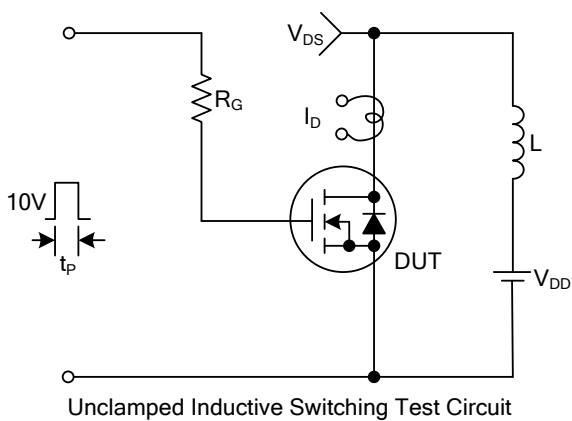
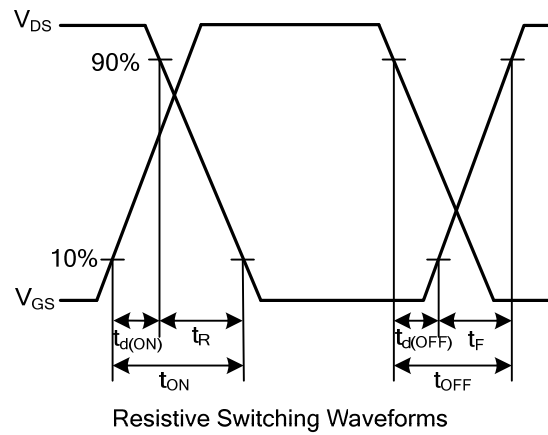
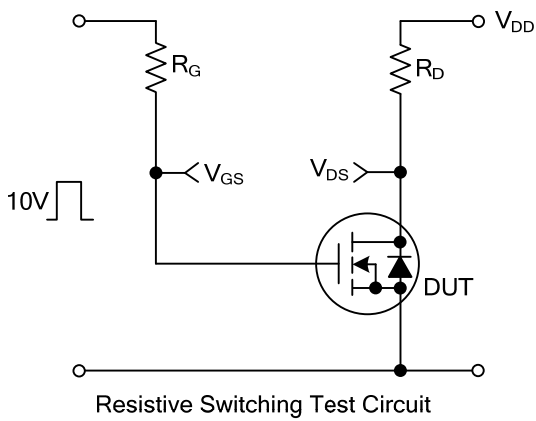
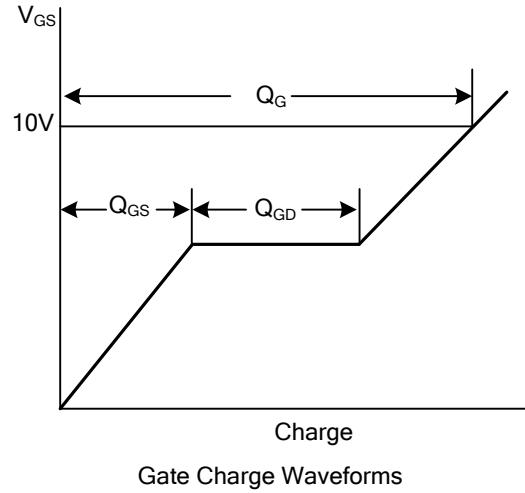
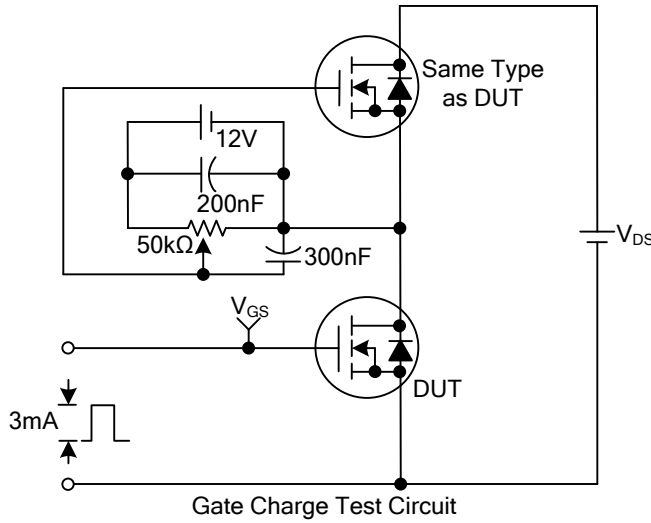

■ TYPICAL CHARACTERISTICS

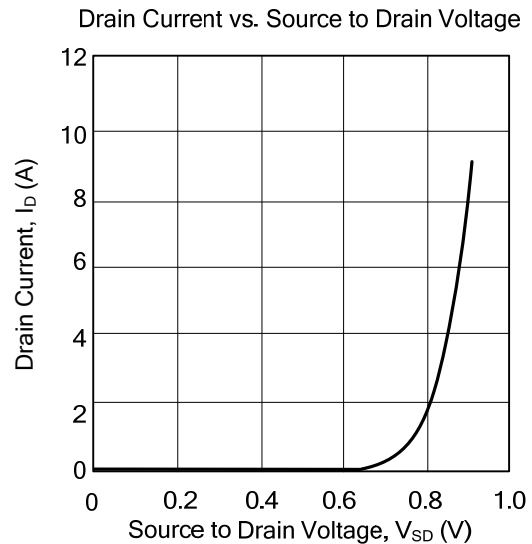
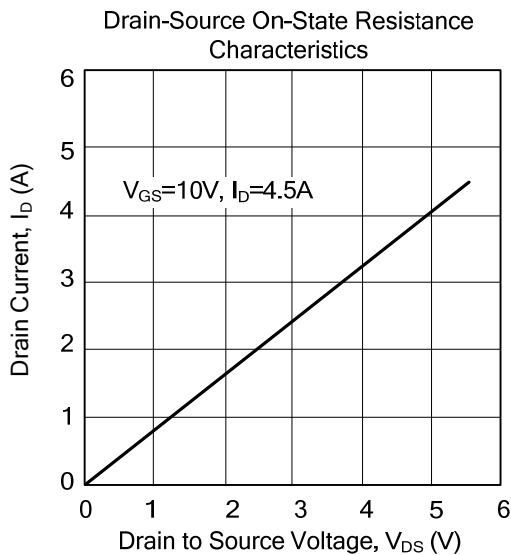
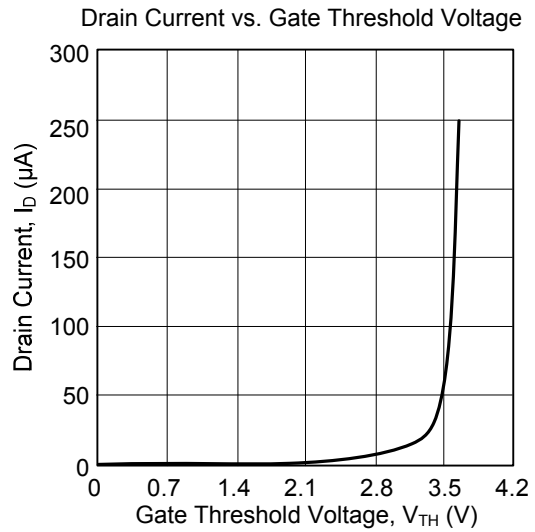
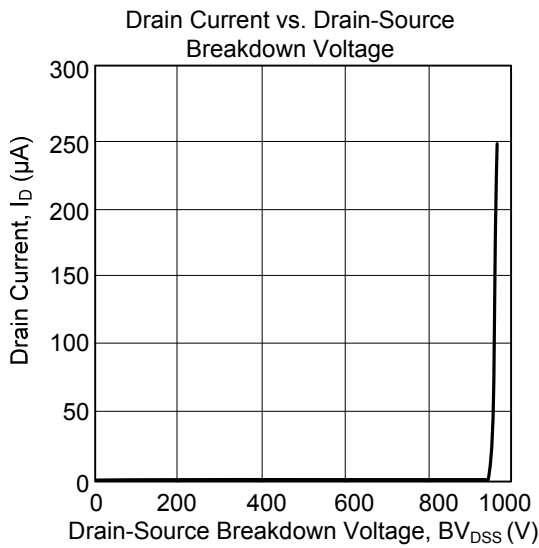

UTC assumes no responsibility for equipment failures that result from using products at values that exceed, even momentarily, rated values (such as maximum ratings, operating condition ranges, or other parameters) listed in products specifications of any and all UTC products described or contained herein. UTC products are not designed for use in life support appliances, devices or systems where malfunction of these products can be reasonably expected to result in personal injury. Reproduction in whole or in part is prohibited without the prior written consent of the copyright owner. The information presented in this document does not form part of any quotation or contract, is believed to be accurate and reliable and may be changed without notice.