

## DM74LS125A Quad 3-STATE Buffer

### General Description

This device contains four independent gates each of which performs a non-inverting buffer function. The outputs have the 3-STATE feature. When enabled, the outputs exhibit the low impedance characteristics of a standard LS output with additional drive capability to permit the driving of bus lines without external resistors. When disabled, both the output transistors are turned off presenting a high-impedance state to the bus line. Thus the output will act neither as a significant load nor as a driver. To minimize the possibility that two outputs will attempt to take a common bus to opposite logic levels, the disable time is shorter than the enable time of the outputs.

### Ordering Code:

Order Number	Package Number	Package Description
DM74LS125AM	M14A	14-Lead Small Outline Integrated Circuit (SOIC), JEDEC MS-120, 0.150 Narrow
DM74LS125ASJ	M14D	14-Lead Small Outline Package (SOP), EIAJ TYPE II, 5.3mm Wide
DM74LS125AN	N14A	14-Lead Plastic Dual-In-Line Package (PDIP), JEDEC MS-001, 0.300 Wide

Devices also available in Tape and Reel. Specify by appending the suffix letter "X" to the ordering code.

### Connection Diagram

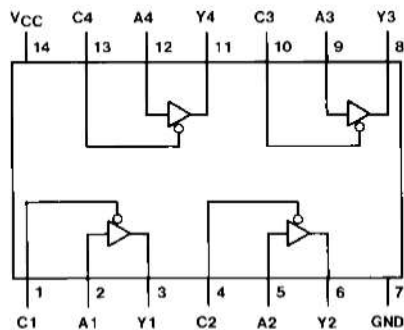

### Function Table

$$Y = A$$

Inputs		Output
A	C	Y
L	L	L
H	L	H
X	H	Hi-Z

H = HIGH Logic Level  
L = LOW Logic Level  
X = Either LOW or HIGH Logic Level  
Hi-Z = 3-STATE (Outputs are disabled)

**Absolute Maximum Ratings**(Note 1)

Supply Voltage	7V
Input Voltage	7V
Operating Free Air Temperature Range	0°C to +70°C
Storage Temperature Range	-65°C to +150°C

**Note 1:** The "Absolute Maximum Ratings" are those values beyond which the safety of the device cannot be guaranteed. The device should not be operated at these limits. The parametric values defined in the Electrical Characteristics tables are not guaranteed at the absolute maximum ratings. The "Recommended Operating Conditions" table will define the conditions for actual device operation.

**Recommended Operating Conditions**

Symbol	Parameter	Min	Nom	Max	Units
$V_{CC}$	Supply Voltage	4.75	5	5.25	V
$V_{IH}$	HIGH Level Input Voltage	2			V
$V_{IL}$	LOW Level Input Voltage			0.8	V
$I_{OH}$	HIGH Level Output Current			-2.6	mA
$I_{OL}$	LOW Level Output Current			24	mA
$T_A$	Free Air Operating Temperature	0		70	°C

**Electrical Characteristics**

over recommended operating free air temperature range (unless otherwise noted)

Symbol	Parameter	Conditions	Min	Typ (Note 2)	Max	Units
$V_I$	Input Clamp Voltage	$V_{CC} = \text{Min}, I_I = -18 \text{ mA}$			-1.5	V
$V_{OH}$	HIGH Level Output Voltage	$V_{CC} = \text{Min}, I_{OH} = \text{Max}$ $V_{IL} = \text{Max}, V_{IH} = \text{Min}$	2.4	3.4		V
$V_{OL}$	LOW Level Output Voltage	$V_{CC} = \text{Min}, I_{OL} = \text{Max}$ $V_{IL} = \text{Max}$ $I_{OL} = 12 \text{ mA}, V_{CC} = \text{Min}$		0.35 0.25	0.5 0.4	V
$I_I$	Input Current @ Max Input Voltage	$V_{CC} = \text{Max}, V_I = 7V$			0.1	mA
$I_{IH}$	HIGH Level Input Current	$V_{CC} = \text{Max}, V_I = 2.7V$			20	μA
$I_{IL}$	LOW Level Input Current	$V_{CC} = \text{Max}, V_I = 0.4V$			-0.4	mA
$I_{OZH}$	Off-State Output Current with HIGH Level Output Voltage Applied	$V_{CC} = \text{Max}, V_O = 2.4V$ $V_{IH} = \text{Min}, V_{IL} = \text{Max}$			20	μA
$I_{OZL}$	Off-State Output Current with LOW Level Output Voltage Applied	$V_{CC} = \text{Max}, V_O = 0.4V$ $V_{IH} = \text{Min}, V_{IL} = \text{Max}$			-20	μA
$I_{OS}$	Short Circuit Output Current	$V_{CC} = \text{Max}$ (Note 3)	-20		-100	mA
$I_{CC}$	Supply Current	$V_{CC} = \text{Max}$ (Note 4)		11	20	mA

**Note 2:** All typicals are at  $V_{CC} = 5V, T_A = 25^\circ\text{C}$ .

**Note 3:** Not more than one output should be shorted at a time, and the duration should not exceed one second.

**Note 4:**  $I_{CC}$  is measured with the data control (C) inputs at 4.5V and the data inputs grounded.

**Switching Characteristics**

at  $V_{CC} = 5V$  and  $T_A = 25^\circ\text{C}$

Symbol	Parameter	$R_L = 667\Omega$				Units
		$C_L = 50 \text{ pF}$		$C_L = 150 \text{ pF}$		
		Min	Max	Min	Max	
$t_{PLH}$	Propagation Delay Time LOW-to-HIGH Level Output		15		21	ns
$t_{PHL}$	Propagation Delay Time HIGH-to-LOW Level Output		18		22	ns
$t_{PZH}$	Output Enable Time to HIGH Level Output		25		35	ns
$t_{PZL}$	Output Enable Time to LOW Level Output		25		40	ns
$t_{PHZ}$	Output Disable Time from HIGH Level Output (Note 5)		20			ns
$t_{PLZ}$	Output Disable Time from LOW Level Output (Note 5)		20			ns

**Note 5:**  $C_L = 5 \text{ pF}$ .

**Physical Dimensions** inches (millimeters) unless otherwise noted

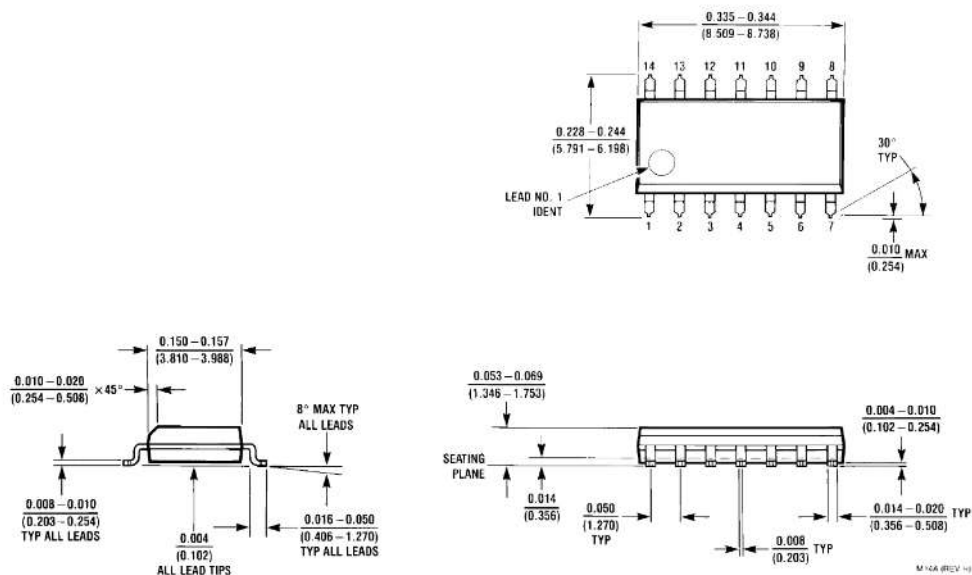

14-Lead Small Outline Integrated Circuit (SOIC), JEDEC MS-120, 0.150 Narrow Package Number M14A

**Physical Dimensions** inches (millimeters) unless otherwise noted (Continued)

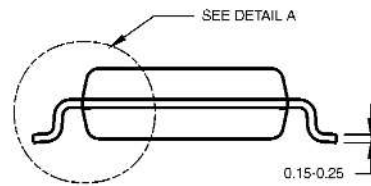
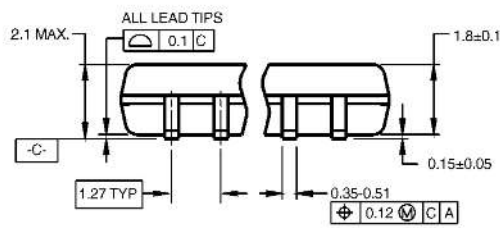
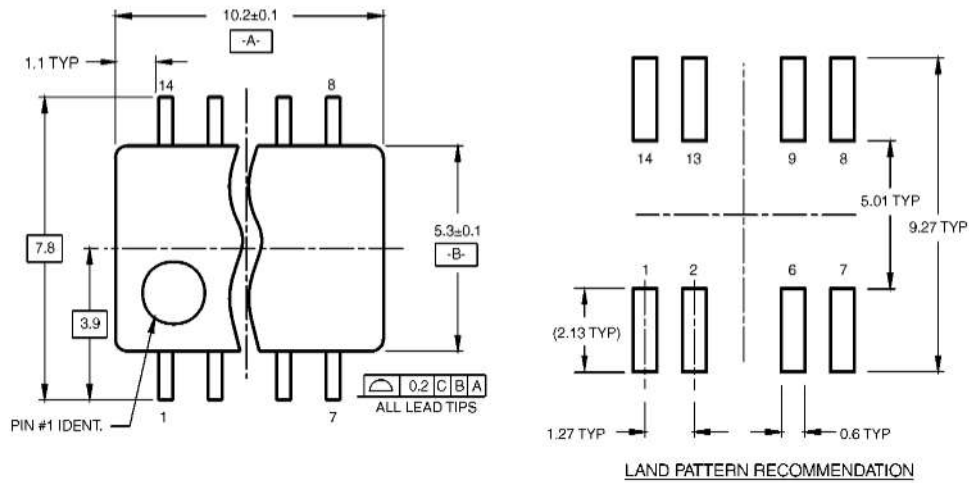

DIMENSIONS ARE IN MILLIMETERS

- NOTES:  
 A. CONFORMS TO EIAJ EDR-7320 REGISTRATION, ESTABLISHED IN DECEMBER, 1998.  
 B. DIMENSIONS ARE IN MILLIMETERS.  
 C. DIMENSIONS ARE EXCLUSIVE OF BURRS, MOLD FLASH, AND TIE BAR EXTRUSIONS.

M14DRevB1

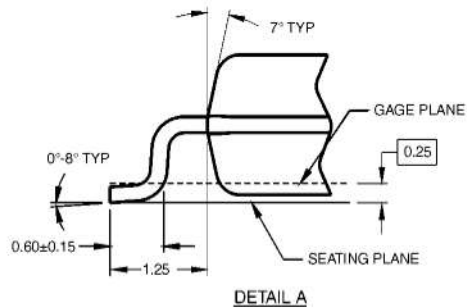

**14-Lead Small Outline Package (SOP), EIAJ TYPE II, 5.3mm Wide  
 Package Number M14D**

**Physical Dimensions** inches (millimeters) unless otherwise noted (Continued)

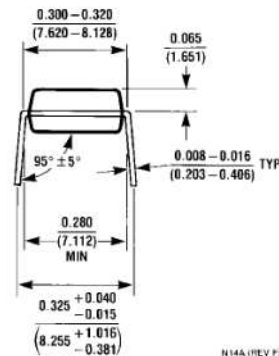
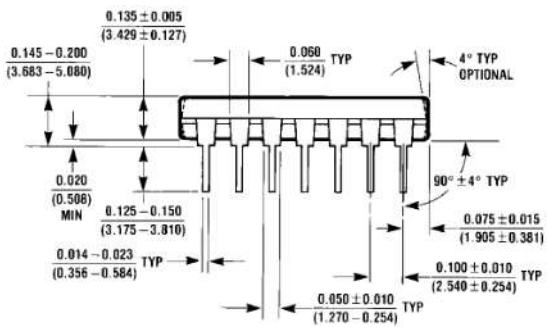
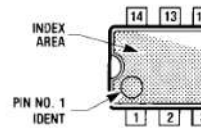
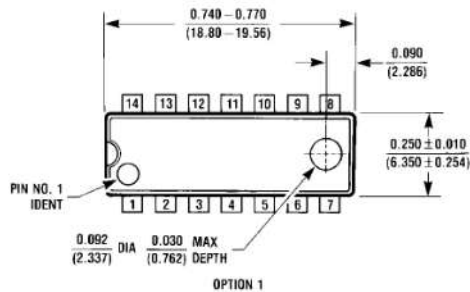

N14A (REV. F)

14-Lead Plastic Dual-In-Line Package (PDIP), JEDEC MS-001, 0.300 Wide Package Number N14A

Fairchild does not assume any responsibility for use of any circuitry described, no circuit patent licenses are implied and Fairchild reserves the right at any time without notice to change said circuitry and specifications.

**LIFE SUPPORT POLICY**

FAIRCHILD'S PRODUCTS ARE NOT AUTHORIZED FOR USE AS CRITICAL COMPONENTS IN LIFE SUPPORT DEVICES OR SYSTEMS WITHOUT THE EXPRESS WRITTEN APPROVAL OF THE PRESIDENT OF FAIRCHILD SEMICONDUCTOR CORPORATION. As used herein:

1. Life support devices or systems are devices or systems which, (a) are intended for surgical implant into the body, or (b) support or sustain life, and (c) whose failure to perform when properly used in accordance with instructions for use provided in the labeling, can be reasonably expected to result in a significant injury to the user.
2. A critical component in any component of a life support device or system whose failure to perform can be reasonably expected to cause the failure of the life support device or system, or to affect its safety or effectiveness.

[www.fairchildsemi.com](http://www.fairchildsemi.com)